

## Dribbling

Each player will dribble around cones as shown below. The players will run this drill twice, once with their right hand and one with their left hand. The diagram below is for the right hand dribble. Reverse the course for the left hand dribble. Player starts at baseline, and is timed with a stopwatch until he/she crosses the baseline at the end of the drill. The two times should be averaged, and the corresponding score below should be entered on the score sheet. Two points can be deducted if the player consistently dribbles with the wrong hand.

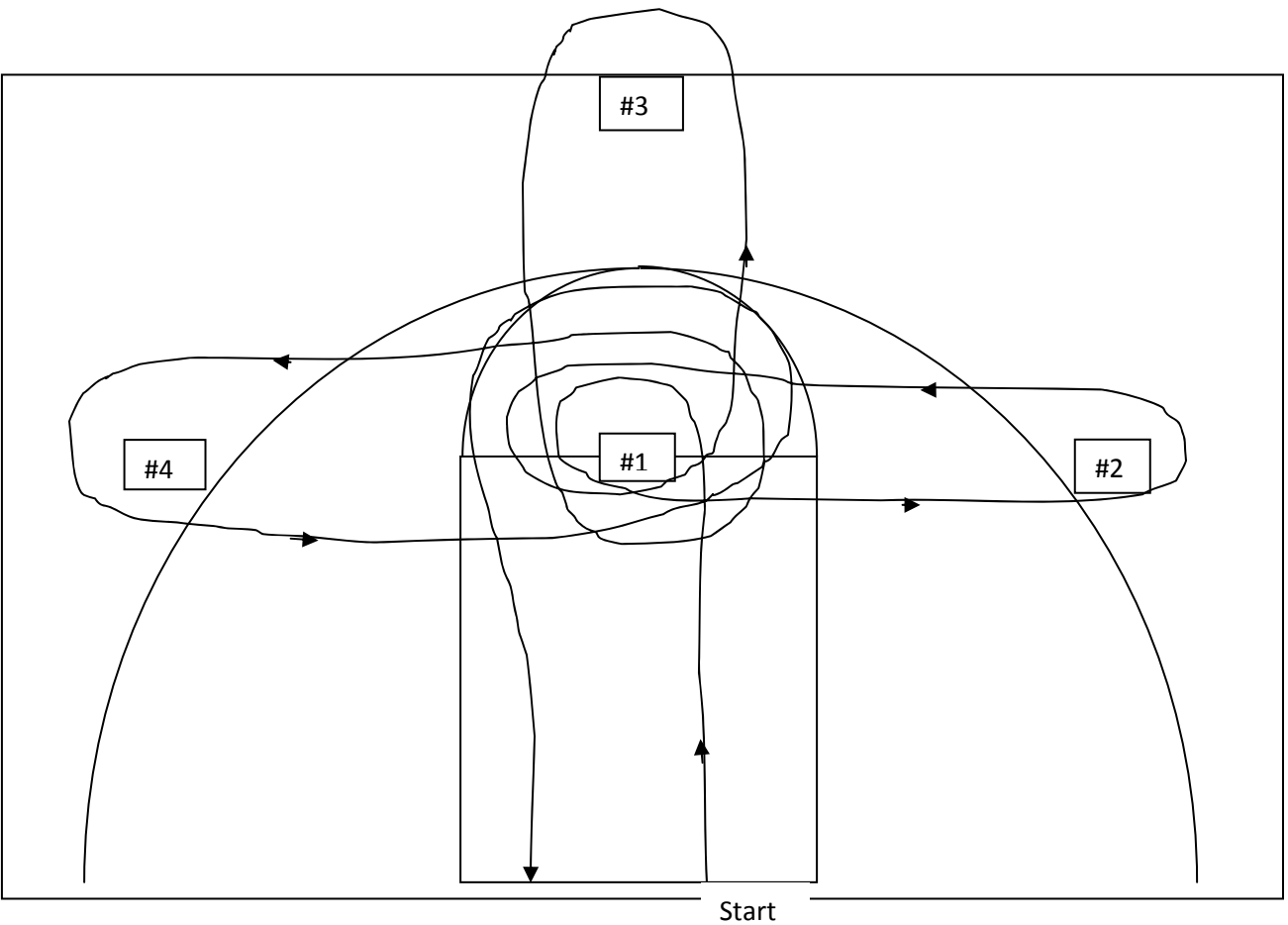

# Layups

Each player will be given a set amount of time (see table) to make as many layups as possible using proper form.

Start at the baseline. Dribble with the outside hand (right on right side, left on left side), attempt a layup with outside hand. Get the rebound and dribble around the other cone from the inside, switching hands to the outside hand and attempting a layup on the other side using the outside hand. Players should jump off their inside leg on the layups. If layups are taken with the incorrect hand, the basket does not count.

Two points can be deducted from the score if players consistently exhibit the following:

- dribbling with the wrong hand
- shooting with two hands
- jumping on the wrong leg on the shot.

Grade	Time
6 <sup>th</sup> /7 <sup>th</sup> /8 <sup>th</sup>	45 seconds

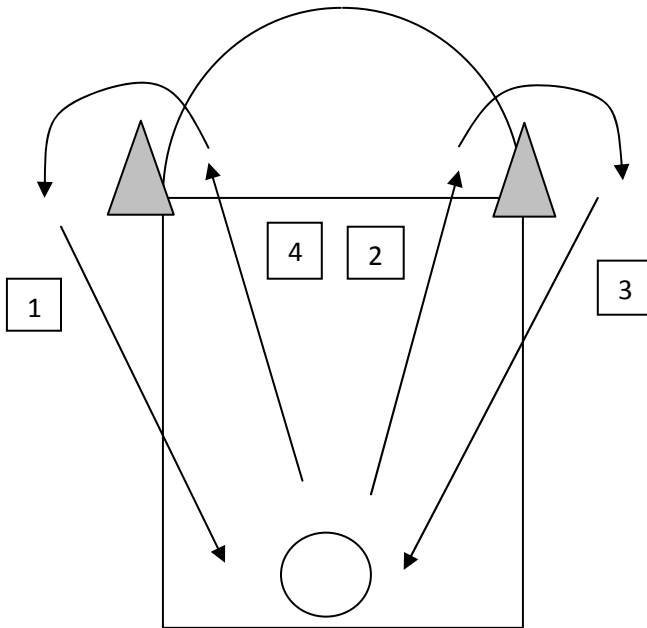

## Shooting- Spot Shots

Untimed drill where each player will shoot from marked locations on the floor. Use tape or cones to mark the spots on the floor.

In addition, each player's form will be evaluated with a possible 2 points being deducted from those who consistently exhibit improper form which typically is shooting with two hands.

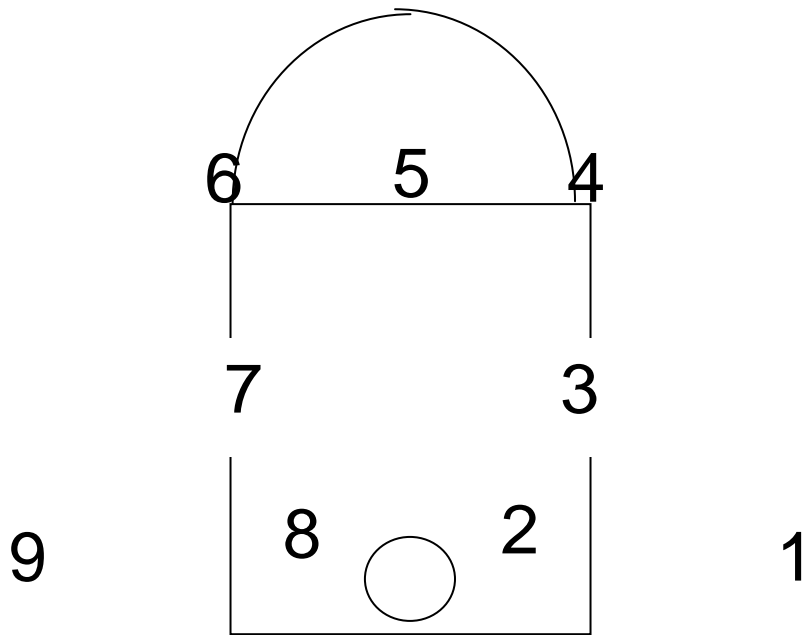

## **Free Throws**

Each player will shoot 2 free throws and then rotate to allow the next player in line to shoot. Each player will go through the line five times accounting for a total of 10 free throws.

In addition, each player's form will be evaluated with a possible 2 points being deducted from those who consistently exhibit improper form which typically is shooting with two hands.