

INTERNATIONAL WOMEN'S LACROSSE RULES AUGUST 2010

**As adopted by the Federation of International Lacrosse and
ratified by all Members of the Federation**

The International Women's Rule Book is compiled and published by the
Federation of International Lacrosse, FIL

In addition to the rules, guidance sections in italics are provided to give
clarity and rule interpretations for umpires, coaches and players.

For convenience and clarity, the feminine gender is used.

Please direct any inquiries, rule suggestions or interpretations to:
womensrules@filacrosse.com
or
FIL administrative Assistant:
admin.assistant@filacrosse.com

Copyright 2011 – The contents of this publication may not be
reproduced or transmitted in any form without the written permission
of the Federation of International Lacrosse.

NOTES

TABLE OF CONTENTS

2011 RULE CHANGES.....	4
1. FIELD MARKINGS.....	7
2. THE GOAL CAGE.....	13
3. THE CROSSE.....	16
4. THE BALL.....	20
5. TEAMS.....	20
6. UNIFORMS AND EQUIPMENT.....	22
7. CAPTAINS.....	24
8. UMPIRES.....	25
9. SCORERS AND TIMERS.....	27
10. DURATION OF PLAY.....	29
11. SUBSTITUTION.....	31
12. START AND RESTART PLAY.....	35
13. SCORING.....	37
14. OUT OF BOUNDS.....	38
15. THROW.....	42
16. CONDUCT OF PLAY.....	43
17. GOAL CIRCLE RULES AND PENALTIES.....	45
18. RESTRAINING LINE RULES AND PENALTIES.....	50
19. MINOR FOUL RULES AND PENALTIES.....	53
20. MAJOR FOUL RULES AND PENALTIES.....	60
21. ADVANTAGE FLAG.....	68
22. MISCONDUCT AND WARNING CARDS.....	72
23. DEFINITIONS.....	77
24. TOURNAMENT RULES.....	83
25. MANUFACTURER'S SPECIFICATIONS.....	86
APPENDICES A – E.....	104

2011 FIL RULE CHANGES

Rule 1.A: Except for the goal line, all field markings will be 5.1 to 10.2 cm wide. It is recommended that all lines be painted white.

Guidance: On multipurpose fields, it is recommended that the women's lines be painted a single contrasting color.

Rule 6: Players may wear close fitting cloth sweat bands, but they may not be worn to cover illegal jewelry. Goalkeeper's shoulder pads may include arm pads.

Rule 11.A: Added: "All substitutions must be made through the substitution area."

Guidance: Players substituting after a goal is scored must enter the game through the substitution area but do not have to wait for the teammates they are replacing to come completely off the field.

Rule 12.A: During the draw, a maximum of five players from each team may be between the restraining lines, the centers and four other players from each team. All other field players must be below either restraining line. Players must not step on or over the center circle line or the restraining lines until the whistle sounds to start play. Both goalkeepers must remain below/goal side of their team's defensive restraining line for the draw.

Guidance: When the game starts or restarts with a free position or a throw at the center line rather than with a draw, players will take positions as they would for the draw and must stand until the whistle sounds to resume play.

Rule 12.A.2.b: If both players draw illegally, and it cannot be determined why the draw was illegal, or an umpire determines that the draw was unsuccessful because it was set incorrectly, the umpire will call time out to reset the draw. Exception: When agreed prior to the game/event, the clock will continue to run after goals if one team is leading by 12 or more goals.

2011 FIL RULE CHANGES

Rule 14.D.1: When the goalkeeper is inside the goal circle and the nearest player to the ball when it crosses the boundary, she will be awarded the ball inside the goal circle to restart play.

Rule 14.E: When a shot or a deflected shot goes out of bounds, and the goalkeeper is inside the goal circle and the nearest player to the ball when it crosses the boundary, she will be awarded the ball inside the goal circle to restart play.

Rule 18.A: A team must not have more than seven attack players below/goal side of the restraining line in their offensive/attacking end of the field. A team must not have more than eight defense players below/goal side of the restraining line in their defensive end of the field. One of these eight players is usually, but not necessarily, the goalkeeper.

Rule 18.B: When a team is offside, the penalties for both attack and defense offside are the same, and the free position is set relative to the spot of the ball when the violation is called. Violation of the restraining line is a minor foul. Offside is an immediate whistle unless the defense is offside when the attack is on a scoring play.

Rule 19.A.5: A player must not allow any part of her body to deliberately impede, accelerate or change the direction of the ball.

Guidance: "Deliberate" implies intent and intent is determined by players' actions on the field. Ball contact from an unexpected deflection may not be deliberate.

Rule 20.A.12.a and 12.b, clarification: When the defense is called for a three second violation and:

- a. The attack player in possession of the ball is above or below the goal line extended, the free position will be set relative to the position of the ball to restart play.
- b. The advantage flag was raised for the violation and the scoring play ends without a further foul or shot on goal, the free position will be set relative to the spot of the ball when the flag was raised.

2011 FIL RULE CHANGES

Rule 20.A.13, added: A player must not use the shaft of the crosse to hit, push, or displace an opponent.

Rule 22.B.2: A player receiving a yellow card must leave the field for a two minute timed penalty suspension; a substitute may not take her place. Her team must play with one less player below/goal side of the restraining lines for the duration of the two minute penalty.

Rule 24.G: For FIL Tournaments, a penalty point system will be in place for players receiving warning cards for personal fouls and to deter unsportsmanlike or dangerous conduct by players.

RULE 25: MANUFACTURER'S SPECIFICATIONS **2010 MODIFICATIONS**

Rule 25.A.8: Sidewall stringing holes: Pockets must be attached to and anchored along the bottom rail of the sidewall through stringing holes. The distance from the bottom of the sidewall to the bottom of the stringing hole shall not be more than 1.0 cm.

Guidance: Decorative holes in the sidewalls that do not meet these specifications may not be used as stringing holes.

Rule 25.D.1.a: Longitudinal leather or synthetic thongs shall be 0.3 cm to 1.0 cm wide. Thongs may now be made of twisted nylon cording.

Rule 25: For all FIL Women's World Events, players may use only those crosses that have been evaluated and approved by the laboratory three months (90 days) prior to the scheduled first day of play.

NOTE: All modifications made to Rule 25 since 2007 are highlighted in gray.

RULE 1: FIELD MARKINGS

- A. The playing area will be marked with a solid lined rectangular boundary, 100 to 122 meters long between end lines and 50 to 60 meters wide between sidelines. Four cones may be used to mark the corners of the field. Except for the goal line, all field marking lines will be 5.1 to 10.2 cm wide. The goal line will be 5.1 cm wide. It is recommended that all lines be painted white. No unauthorized lines or marks may be added to the field. A playing area of 122 x 60 meters is desirable for FIL events. (Rule 24)
- B. The playing area must be flat and free of stones, glass and protruding objects. The team bench sideline boundary must be 4 meters away from the scorer's table. There must be 4 meters of space beyond the opposite sideline and spectators. There must be 2 to 4 meters of space beyond the end line boundaries and any natural or artificial objects, such as trees, bushes, athletic tracks, fences, spectators, or stands.
Guidance: Spectators must stay back at least 4 m from the sidelines and are not allowed directly behind the team benches or score table. No spectators are allowed behind the end lines unless permanent seating is available.
- C. A goal line will be marked at each end of the field. The goal lines will be no less than 82 meters and no greater than 92 meters apart. The goal lines will be 1.83 meters in length and will be marked parallel to the end lines. (Rule 2)
- D. There must be 9 to 15 meters of playing space behind each goal line running the full width of the field. The 9 to 15 meters of playing space behind each goal line is measured from the back, outside edge of the goal line extended to the front, inside edge of the end line.
- I. Two small circles 15 cm in diameter must be added to the field behind each goal, 4 meters in from the boundary and 11 meters from the center of the goal line. These marks indicate the nearest spot to restart play when the playing space from the goal line to the end line boundary is less than 15 meters.
- E. Around each goal line, a goal circle will be marked. It will have a radius of 3 meters measured from the center back edge of the goal line to the outside edge of the goal circle. (Diagram 4)

RULE 1 / FIELD MARKINGS

- F. Restraining lines will be marked at each end of the field, 27 meters up field from each goal line. These solid lines will extend across the full width of the field. The 27 meters is measured from the back edge of the goal line to the front/midfield edge of the restraining line.
- G. In the center of the field, a center circle will be marked and have a radius of 9 meters when measured from the center of the circle to its outside edge. Through the center of this circle, a center line 3 meters in length will be marked parallel to the goal lines.
- H. Directions for marking the 11 Meter Area and the Marking Area. (Diagram 2)
1. Locate D, a point on the center, back edge of the goal line. Using point D as the center, draw a circle with a radius of 3 meters measured from point D to the outside edge of the goal circle. Lightly mark lines AB and DB as shown.
 2. Using point D as the center, lightly draw a semicircle with a radius of 11 m measured from point D to the outside edge of the semicircle. Mark point G (perpendicular to the center of the goal line at D).
 3. Connect A to B and extend this line to the 11 meter semicircle. Mark point C on each side as shown. (Lines BC are at a 45° degree angle to the goal line extended; $\angle EBC = 45^\circ$)
 4. Draw a hash mark 31 cm in length at point G. This hash mark will be perpendicular to the center of the goal line and bisected by the 11 meter semicircle at point G. Make three additional hash marks on the semicircle every 4 meters on each side of point G. There will be a total of seven hash marks as shown.
 5. At point H, 11 meters from the center of the goal circle on the goal line extended, draw two additional 15 cm marks that are perpendicular to the goal line extended. (These marks are not hash marks but indicate where the 11 meter semicircle would intersect the goal line extended if the semicircle was drawn as a solid line.) This entire semicircle is called the "11 Meter Area".

RULE I / FIELD MARKINGS

6. Mark the curve of the arc with a solid line from C to C. Mark each side of the arc with a solid line from B to C. This smaller enclosed area is called the “Marking Area”. The ‘pie’ shaped area, $\angle HBC$, is referred to as “11 Meters Outside the Marking Area”.

7. Measurements:

A-G = 14.0m

B-C = 8.65m

D-H = 11.0m

A-C = 12.85m

D-G = 11.0m

D-E = 15.0m

A-B = 4.2m

D-C = 11.0m

$\angle EBC = 45^\circ$

I. 15 Meter Fan:

Using point D as the center, draw a semicircle with a solid line and radius of 15 meters measured from D to the outside edge of the semicircle. This entire semicircle is called the “15 Meter Fan” and intersects the goal line extended at point E, as shown. The 15 meter fan designates the maximum distance for calling obstruction of the free space to goal. It also defines the part of the advantage flag area above/in front of the goal line extended. (Diagram 2)

RULE I / FIELD MARKINGS

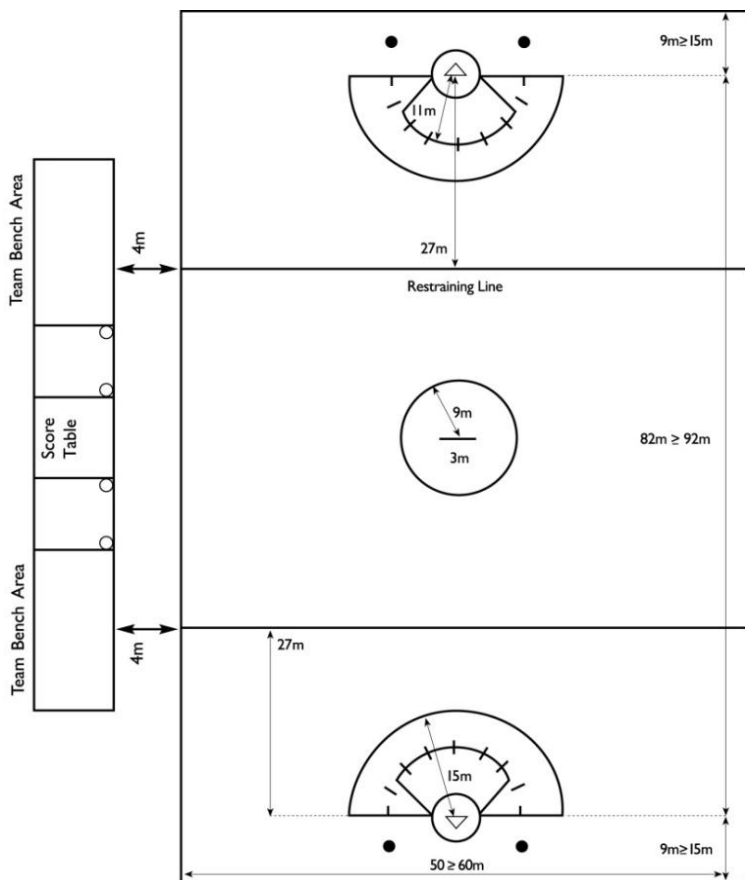

Guidance: No additional lines or marks may be added to the field.

Diagram I
Field Markings

RULE 1 / FIELD MARKINGS

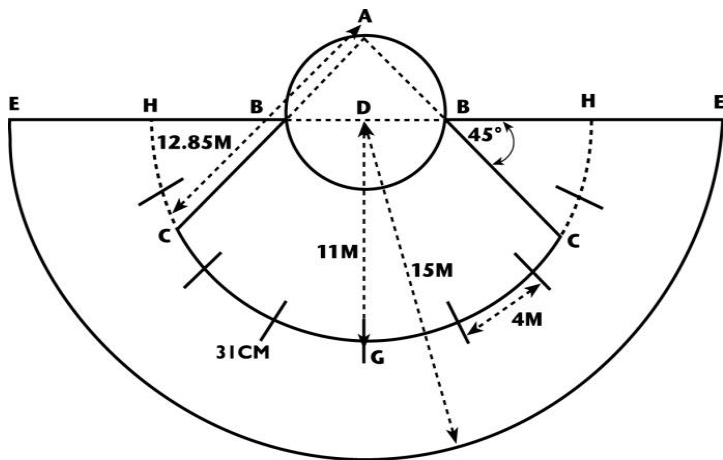

Diagram 2
Directions for Marking the 11 Meter Area, the
Marking Area and the 15 m Fan

- J. A scorer's and timer's table will be set at midfield in a marked 5 x 5 meters box that is set 4 meters outside the boundary on the teams' bench side of the field.

Each team's substitution area will be 4 x 5 meters and defined by two cones/markers placed 4 meters apart and even with the scorer's/timer's table extended. Players must exit and enter the game through this gate area only. Players waiting to substitute must stand behind the markers and are the only team/bench personnel permitted in the substitution area. The coaches and other team bench personnel must remain outside the boundary, behind the level of the score table extended and inside the team bench area. The team bench areas will be 28 meters long and 5 meters deep.

RULE 1 / FIELD MARKINGS

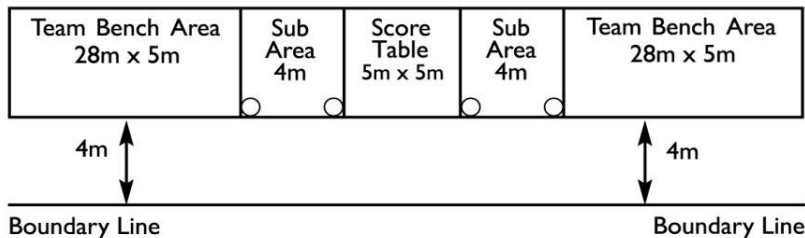

Diagram 3
Scorer's/Timer's Table, Substitution Area & Team Bench Area

NOTE: Domestically, FIL emerging and developing nations may choose to play the following modifications:

1. Teams play on the smaller field, 82m between goals.
2. A full squad of 16 players.
3. Ten players per team on the field at one time. One player is usually a goalkeeper.
4. A team must not have more than seven attack players below/goal side of the restraining line in their offensive end of the field or more than eight defense players below/goal side of the restraining line in their defensive end of the field. One of these eight players is usually, but not necessarily, the goalkeeper.

For all FIL Events, the official FIL Women's Rules will be played.

RULE 2: THE GOALS

- A. A goal cage will be placed in each goal circle.
1. A goal cage consists of two vertical posts/pipes joined at the top by a rigid crossbar. The posts/pipes will be 1.83 meters apart and the top horizontal crossbar will be 1.83 meters from the ground. All measurements are inside measurements. The goal posts/pipes and crossbar will be 5.1 cm square or 5.1 cm in diameter and must be silver or painted white or orange.
 - a. If a freestanding goal is used, all ground, side and center back supports must be padded their entire length with material that limits the rebound of the ball. It is not necessary to pad goals with flat or angled ground supports that prevent the ball from rebounding off the supports into the playing area. No supporting braces should be placed in the corners of the goal that would prohibit a goal from being scored. (Diagram 5)
 2. Mesh cotton or nylon goal netting must not be larger than 4 cm. The goal net must be securely attached to the posts/pipes, the crossbar and to a point on the ground 2.1 meters behind the center of the goal line. The net should be strung to limit the rebound of the ball.
 - a. Any structure supporting the net behind the goal must allow the goalkeeper to move freely in the back part of the goal circle.
 3. The goal line will be drawn between the two goal post/pipes and must be continuous with them and the same width as the goal posts/pipes, 5.1 cm (Rule 1.A)

RULE 2 / THE GOALS

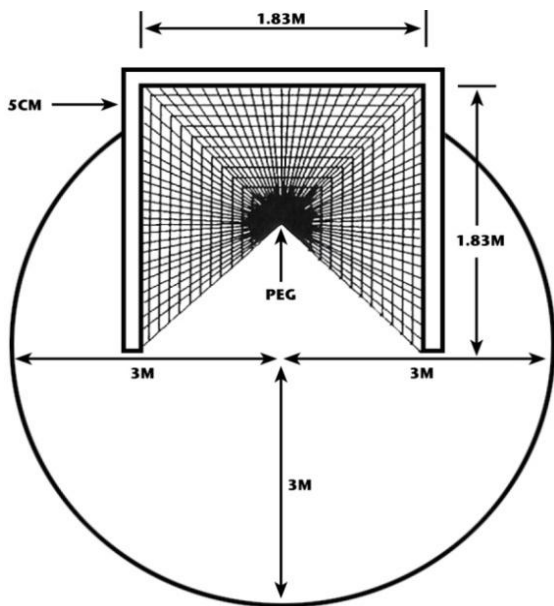
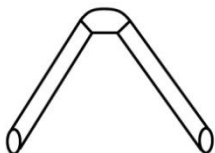

Diagram 4
Goal Circle and Goal Cages
Rule 2

RULE 2 / THE GOALS

SUPPORTS MUST BE PADDED



Rounded Pipes

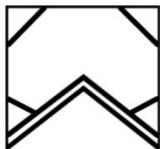

Darkened supports must be padded the entire length with material that limits the rebound of the ball.

SUPPORTS WHICH DO NOT REQUIRE PADDING



Flat Supports where the bottoms are flat metal, not pipes.

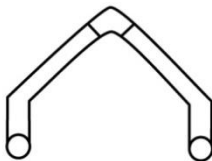

Angled Ground Pipes which prevent the ball from re-entering the playing area after hitting the ground.

Diagram 5
Goal Supports

RULE 3: THE CROSSE

The full crosse specifications are in Rule 25: Manufacturer's Specifications. Only those aspects of the crosse specifications that are necessary and useful for umpires, coaches and players during a game are included below.

A. All Field Crosses:

The primary intent of the field crosse specifications is to ensure that the ball moves freely within all parts of the head and pocket so that the ball may be dislodged from a crosse without an excessively forceful check. A crosse that has been altered in such a way as to give an unfair advantage to a player is illegal.

1. The head of the field crosse will be constructed of wood, plastic, fiberglass, nylon, leather, rubber, gut, and/or any other synthetic material.
2. The head of a field crosse will be triangular in concept. (Rule 25, Diagrams 12 & 13)
 - a. The inside width between the sidewalls of the head must continually increase from the center of the bridge or ball stop to the widest point at the top of the head. At the widest point at the top of the head, the inside width between the walls of a plastic/molded head crosse will be 16 cm minimum and 15 cm to 16 cm for a wooden crosse.
 - b. There may be no protrusions or outcroppings on the inside surface of the sidewalls. The sidewalls may not be lined with any additional material.
3. The handle of the field crosse will be 'nominally' straight and may be constructed of wood, metal alloy or other composite material. The crosse will not have sharp or protruding parts or edges and will not be dangerous to players in any way.

*Guidance: A *bent* handle may only be used with the heads that are specifically designed to accommodate them. *Bent* handles are head and manufacturer specific.*

 - a. Recessed metal screws with rounded heads will be used to attach the head of a plastic molded head crosse to the handle. The butt ends of all handles will have an end cap, be taped or sanded smooth, if wood.

RULE 3 / THE CROSSE

4. The overall length of the field crosse will be 0.9 m / 90 cm minimum to 1.1 m / 110 cm maximum. End caps are included when measuring the overall length of a crosse.
Guidance: Junior players who are under the age of 15 may use a crosse shorter than 0.9 m to allow it to fit comfortably along the length of the player's arm.
5. The pockets of all field crosses will be strung with 4 or 5 longitudinal leather and/or synthetic thongs and 8 to 12 knots/stitches of cross lacing. Mesh pockets are not allowed.
 - a. Longitudinal thongs shall be 0.3 cm to 1.0 cm wide. Thongs must not touch and must 'nominally' be evenly spaced along the length and across the width of the head. Loose ends of thongs may not be woven back up through the pocket of the crosse and during play must be secured to the handle of the crosse. (Rule 25, Diagram 12).
 - b. Cross-lacing in a traditionally strung pocket is defined as 8-12 knots/stitches, where two strings intertwine at a common place on a thong and evenly spaced diamonds. (A 'diamond' is the shape formed between longitudinal knots on a thong and horizontal knots.)
 - c. Cross-lacing in a pre-manufactured detachable pocket is defined as 8-12 evenly spaced pocket nylon laces that are sewn or traditionally woven between evenly spaced longitudinal thongs. Extra lengths of sidewall nylon ties must be cut to 4 cm maximum.
 - d. Pockets must be attached to and anchored along the bottom rail of the head through stringing holes. The distance from the bottom of the sidewall to the bottom of the stringing hole shall not be more than 1.0 cm.
Guidance: Decorative holes in the sidewalls that do not meet these specifications must not be used as stringing holes.
6. Field crosses will have no more than two separate shooting/throw strings. Shooting/throw strings will not be rolled or coiled more

RULE 3 / THE CROSS

than twice between each thong. Flat hockey or boot laces may not be used as shooting/throw strings.

- a. Both shooting/throw strings must be attached in the upper third of the head, or the top shooting/throw string must be attached in the upper third of the head, and the bottom shooting/throw string may be an “inverted U” in shape and must be attached in the upper one-half of the head, as measured from the top, outside edge of the scoop. (Rule 25, Diagram 16)
7. The field crosse meets specifications if:
- a. It complies with the criteria in this rule and in the Manufacturer’s Specifications for field crosses as approved by the FIL in Rule 25.A-D
 - b. The top of the ball, when dropped into the pocket of a horizontally held crosse, must be visible and remain above the top of the entire wooden or plastic sidewall wall after reasonable force with one hand has been applied to and released from a ball.
 - c. The ball must move freely within all parts of the head and pocket, both laterally and along its full length. The ball must not become wedged between the walls under the guard or the bridge of a wooden crosse, or in the ball stop, or under the walls of a plastic/molded head crosse. The ball must easily fall out of the pocket of the crosse when the crosse is turned upside down.
8. At any time during play, an umpire may take time out to inspect the pocket of a field crosse, or any player on the field may request an umpire to inspect the pocket of an opponent’s crosse. If, at any time during play, the ball becomes lodged in a field player’s crosse, the crosse no longer meets specifications. The umpire will take time out to remove the illegal crosse to the scorer’s table. To resume play, the opponent nearest to the ball will be awarded a free position for a minor foul. (Rules 19.A.14, 19.A.15 & 19.A.16)

RULE 3 / THE CROSSE

B. Goalkeeper's Crosse

1. The crosse will be constructed of wood, plastic, fiberglass, nylon, leather, rubber, gut, and/or any other synthetic material.
2. The handle of the crosse will be straight and may be constructed of wood, metal alloy or other composite material. Recessed metal screws with rounded heads must be used to attach the head to the handle. The butt end of the handle will have an end cap, be taped or sanded smooth, if wood.
3. The crosse must not have sharp or protruding parts or edges, must not be dangerous to players in any way.
4. The overall length of the crosse will be 0.9 meters/90 cm minimum to 1.35 meters/135 cm maximum.
5. The entire head of the crosse will be triangular in concept. The inside width between the sidewalls of the head must continually increase as measured from the center of the bridge or the ball stop to the widest point at the top of the head.
6. The pocket of the crosse may be strung traditionally with 6 or 7 longitudinal leather or synthetic thongs and 8 to 12 knots/stitches of cross-lacing, or the pocket may be mesh.
7. The goalkeeper's crosse may have more than two shooting/throw strings and flat hockey/boot laces may be used as shooting/throw strings. There are no restrictions regarding the design or placement of shooting/throw strings in the pocket of the crosse.
8. The goalkeeper's crosse meets specifications when:
 - a. It complies with the criteria in this rule and in the Manufacturer's Specifications for goalkeeper crosses as approved by the FIL in Rule 25.E.
 - b. The ball moves freely within all parts of the head/pocket, both laterally and along its full length.
 - c. The crosse with the ball in it is held at eye level with the long axis of the stick vertical to the ground, and more than one half of the ball is visible above the ball stop.

RULE 4: THE BALL

- A. The ball will be solid, smooth rubber and may be any solid color. For FIL tournaments, the color of the ball must be solid yellow. (Rule 24)
1. The circumference of the ball will not be less than 20 cm or more than 20.3 cm.
 2. The ball will weigh not less than 142 grams or more than 149 grams. It must have a bounce of not less than 1.1 meters and not more than 1.3 meters when dropped from 1.8 meters onto concrete at a temperature of approximately 18° C to 23° C.

RULE 5: TEAMS

- A. A game is played between two teams. For FIL events, a roster of eighteen (18) players constitutes a full team; the remaining six (6) are substitutes. Any number of players up to twelve (12) are permitted on the field at the same time. One of the twelve players on each team may be a goalkeeper. If a team chooses to play without a goalkeeper, an unprotected field player/ **'deputy'** may only enter the goal circle according to the criteria in Rule 17.A.4 and must never enter the goal circle to defend a shot. (Rule 23: Definitions)

RULE 5 / TEAMS

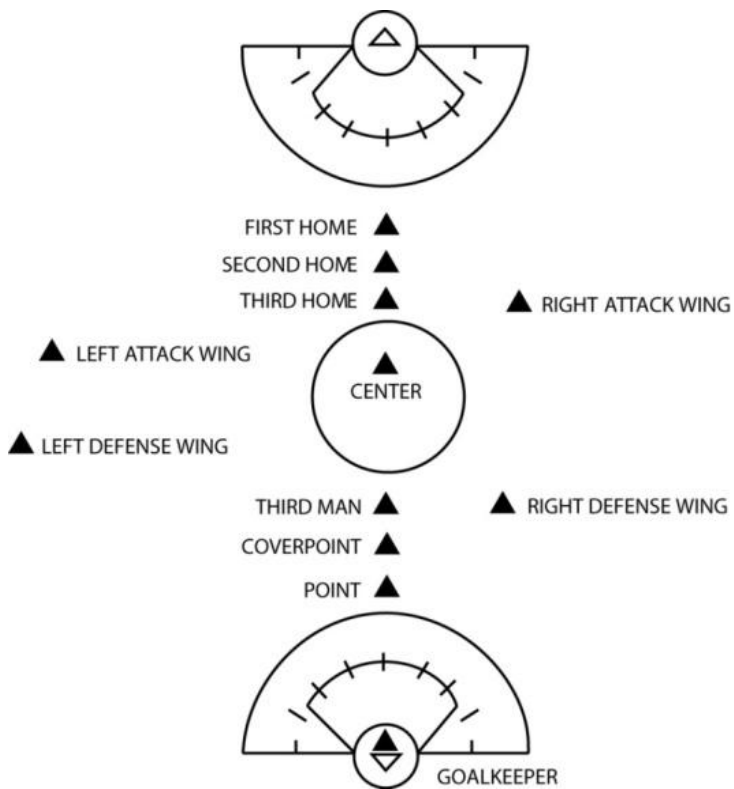

**Diagram 6
Teams**

RULE 6: UNIFORMS AND EQUIPMENT

- A. With the exception of the goalkeeper, all team members must be dressed uniformly. The goalkeeper's shirt must be the same color as her team's top and must be worn over her chest and any shoulder/arm pads. The bottom of her uniform must be the same predominant color of her team's kilt or shorts, or be a solid dark color.
- B. Each player's uniform shirt must be numbered identically on the front and back. Each team member will have a different number and the color of the numbers must clearly contrast with the color of the shirts. If a team wears a patterned shirt, the numbers must be superimposed on a solid, clearly contrasting color block background.
- I. Numbers must be a solid block font. Numbers on the center front of the shirt must be at least 15 cm tall, and numbers on the center back of the shirt must be at least 20 cm tall. For FIL Tournaments, numbers 1-40 only are permitted on team shirts. (Rule 24)
- C. All visible garments worn on the field are considered to be part of the team uniform. All Visible garments worn under the kilt or shorts must be the same predominant color as the kilt/shorts, or be one solid dark color. All visible undergarments worn under the uniform shirt must be the same predominant color as the uniform shirt. All players wearing visible undergarments must be dressed in the same solid color.
Guidance: This ruling does not apply to medical sleeves.
- D. Players must wear shoes with plastic, metal, leather or rubber cleats/studs. Spikes are not permitted. Regardless of their composition, the exposed surface of all studs/cleats must be smooth.
- E. All players, including the goalkeeper, must properly wear a professionally manufactured intra-oral mouth guard that fully covers the upper jaw teeth. Mouth guards must not be altered to decrease protection and field players must remove protruding tabs. Close-fitting gloves, nose guards, and eye guards may be worn. Field players are not permitted to wear headgear or face masks.
- I. Players choosing to wear eye guards may only wear eye guards that comply with all safety aspects in FIL Rule 6.H.

RULE 6 / UNIFORMS & EQUIPMENT

Guidance: Eye guards worn during an FIL contest must comply with the safety aspects listed in Rule 6, or meet certification requirements of any country, organization or standard. However, the FIL does not guarantee the safety of the eye guard to the player wearing them or other players. The FIL does not monitor the safety or effectiveness of any eye guards, such as the ability to withstand impact from a ball or a crosse, nor does the FIL review or approve the certification process of any country, organization or standards organization.

A player may wear prescription glasses or sunglasses, and shatter resistant frames/lenses are strongly recommended.

2. Additional protective devices warranted on genuine medical necessity will be evaluated before the game and may be worn provided the umpires agree that the equipment is not dangerous to other players. All protective devices must be close fitting and padded where necessary and must not be of excessive weight.
- F. Players may wear securely taped medical alert jewelry with information clearly visible and close fitting cloth sweat bands. They must remove any other soft jewelry, necklaces, earrings, bracelets, and watches. Rings must be taped securely to the player or be removed. Flat barrettes or hair slides are legal. Hats/visors with soft neoprene brims may be worn. The umpire may rule any hair or body decoration as dangerous to the player or to others and remove it from the field of play. If applicable, the player will be penalized for a minor foul.
- Guidance:* Sweat bands may not be worn to cover illegal jewelry.
- G. The goalkeeper must wear a chest or body pad, a helmet with facemask, and an attached throat protector. The distance that the throat protector hangs from the helmet must be less than the diameter of the ball. In addition to the attached throat protector, a wrap-around type throat protector may be worn.
1. The goalkeeper may wear padded gloves, shoulder/arm pads and leg pads. All padding must fit securely and not increase the width of the goalkeeper's body beyond the thickness of the padding. The maximum thickness of padding is 3 centimeters. Padded gloves must be tied securely at the cuff and must not have any webbing.

RULE 6 / UNIFORMS & EQUIPMENT

- H. No equipment, including protective devices, may be used unless it complies with Rule 6, manufacturer's specifications, and the umpires agree that the equipment is not dangerous to other players.

RULE 7: CAPTAINS

Each team will designate one speaking captain for the game. The designated captain may choose to wear a distinctive armband. The captain's number will be noted on the official team score sheet.

- A. The captain will:
1. Meet with the charge/head umpire to call the coin toss for choice of end to defend. The visiting or lower seed team captain will call all coin tosses.
 2. Meet with the umpires to agree on the length of playing time and halftime intermission.
 3. Meet with the umpires to be informed about the safety and use of protective equipment that will be used during the game.
 4. Indicate that her team is ready to play at the beginning of each half.
 5. Indicate a substitute for an injured player or suspended player.
 6. Confer with the umpires if weather conditions or any other extenuating circumstances make the continuation of the game questionable. (Rule 10.F)
 7. While on the field, be permitted to request a team time out directly to the umpire after a goal has been scored. A coach may request a team time out through the scorer's table. (Rule 10.H)
 8. Approach the umpires for clarification of rules during a team time out, at halftime, and immediately following the game. A coach may request a rules clarification from the umpires during half-time and at the end of the game, but not during a team time out. (Rule 8.A)
 9. When a team receives their first green card for delaying the game or other persistent minor fouls, a "g" will be written next to their captain's name on the team score sheet. (Rule 22.D.1)

RULE 8: UMPIRES

The umpires will enforce the rules in accordance with the procedures and guidelines set forth by the FIL. The umpires are solely responsible for judging safe and fair play, and **the umpires' decisions are final and without appeal.**

NOTE: *The FIL women's sector is currently developing an appeal process should there be a misapplication of the rules. Any changes to the women's rules in this regard will be available to countries on the FIL website when finalized and accepted by member nations.*

A. The umpires will:

1. Be in charge of a game 30 minutes prior to the start of the game.
2. Prior to the game, inspect the grounds, goals, the ball, crosses, clothing, boots/shoes, jewelry and all protective equipment to ensure they comply with the rules

Guidance: *Careful inspection of all equipment prior to the start of the game eliminates unnecessary delays and penalties. All crosses must be measured and pockets checked, regardless of whether or not they will be used in the game.*

To check crosses, players form a line and hold their crosses raised horizontal at shoulder height. The umpire drops a ball into each of the crosses. The top of the ball must be seen and remain above the entire top edge of the wooden or plastic sidewall after reasonable force with one hand has been applied to and released from the ball. The ball must move freely within all parts of the pocket and head. The ball must easily fall out of the pocket when the crosse is turned upside down. Umpires must also look for rough or sharp edges on any part of the crosse.

If the crosse is illegal, the player moves away from the line. All players with illegal crosses or equipment will remain together and adjust their equipment for re-inspection by the umpire. If a crosse cannot be made legal prior to the start of the game, the crosse must remain at the scorer's table for the duration of the half. If a crosse can be made legal during halftime, the crosse may be rechecked and used in the second half and overtime.

3. Agree about the safety of protective equipment warranted on genuine medical necessity. (Rule 6)

RULE 8 / UMPIRES

4. Ensure that the scorer and timer understand their responsibilities.
5. The charge/head umpire will conduct all coin tosses with the captains, and the visiting team will call all coin tosses.
6. When three umpires call a game, the charge/head umpire will begin the game in the center position, and they will rotate their field positions clockwise following every goal or every two goals. When two umpires call a game, the charge/head umpire will be on the table side of the field, and they will officiate on the same side of the field for both halves of the game.
7. Agree with the captains and/or coaches on the length of playing time and halftime, and agree whether or not to stop the clock after goals if one team is ahead by 12 or more goals. (Rule 10.D)
8. Confer with the captains and/or coaches if weather conditions or any other extenuating circumstances make the continuation of the game questionable. If a game must be interrupted or suspended, the umpire's decision is final. (Rule 10.F)
9. Officiate the game in accordance with the FIL women's rules.
10. Report goals and player warnings or suspensions to the scorer.
11. Be available to clarify rules for the captains during a team time out and for captains and coaches during halftime and immediately following the game.
12. Make the game official by signing the team score sheet.
13. Wear a black and white vertical stripe (2.5 cm) shirt and/or jacket, a black kilt, appropriate length black shorts or black long pants. Black or white visors/hats, black or white short socks or long black socks may be worn. All other garments and accessories must be black. It is recommended all umpires be similarly attired.

RULE 9: SCORERS AND TIMERS

A. The scorer will:

1. Record the rosters, names and shirt numbers, of both teams on the team score sheet 20 minutes prior to the start of the game.
2. Keep an accurate record of the goals scored and team time outs, and display an accurate score for all participants.
3. Record all warning and suspension cards, the time on the game clock when the player is suspended and the time the player or her substitute may re-enter the game. Inform the carded player and her coach at what time the penalty suspension will expire.

(Rule 22)

***Guidance:** Inform the nearest umpire when a yellow card is a player's second and a green card is a team's third.*

Cards for personal fouls are: yellow -"y"; yellow/red -"y/r", and red -"r". Cards for delay of game or other persistent minor foul violations are: green-"g"; green/yellow- "g/y"; and green/red-"g/r".

4. Inform the nearest umpire when there has been an illegal substitution. An extra player, an ineligible suspended player or an illegal player, one incorrectly or not listed on the team score sheet, are all illegal substitutes. (Rule 11.A)

B. The timer will:

1. Prior to the game, confirm with the umpires the length of each half and overtime, when played.
2. At each draw, start the clock on the umpire's whistle. (Rules 10.D.1, 12.A.2.b & 19.A.9)
3. Stop the clock at the umpire's whistle and goal signal after each goal for the entire game. **Exception:** Upon agreement prior to the game or event, the clock will continue to run after goals if one team is leading by 12 or more goals. Timers will notify the umpires when there is a 12 goal difference. (Rules 10.D.1)
4. During the last two minutes of each half, stop the clock on every stoppage of play. When play is stopped prior to the last two minutes, the timer will stop the clock when it reaches two minutes if play has not resumed. The clock will restart at the umpire's whistle.

RULE 9 / SCORERS & TIMERS

5. Notify the umpires when there are two minutes remaining in each half and display a yellow flag at the scorer's table.
6. Notify the umpires when there are 30 seconds remaining in each half and replace the yellow flag at the scorer's table with a red flag.
Guidance: On game fields where a score board with an electric clock is clearly visible, use of the yellow and red flags is optional when agreed prior to the game or event.
7. The timer or reserve umpire will verbally count down the last 10 seconds of each half to the nearest umpire and sound the horn when time is expired.
Guidance: The horn will indicate the end of time in each half. When a horn is not available, the field umpire's whistle (three short blasts) will indicate the end of time. (Rule 10.1)
8. Notify the umpires and sound the horn when two minutes remain during halftime intermission. (Rule 19.A.21)
9. Time the recovery time allowed for an injured player. A field player is allowed up to two (2) minutes, and the goalkeeper up to five (5) minutes recovery time.
10. Time the penalty suspensions of:
 - a. Two minutes before the suspended player or a substitute may enter the game following a personal yellow card.
 - b. Five minutes before a substitute may enter the game following a personal yellow/red card shown together.
 - c. Ten minutes before a substitute may enter the game following a personal straight red card.
 - d. Five minutes before the suspended player or her substitute may enter the game following a team green/red card.
 - 1) Inform the nearest umpire if a suspended player or a substitute re/enters the game before the timed penalty suspension expires. The player or her team must reserve the penalty suspension. (Rules 22.B. & 22.D)
 - 2) Inform the umpires if a penalty suspension will carry over into the second half.
11. Time the 90 second team time out following a goal. (Rule 10.H)

RULE 9 / SCORERS & TIMERS

12. When an umpire sounds the whistle and signals time out, stop the clock for unusual circumstances or those required by Rule 10.E. Play will resume according to Rule 12.C.

RULE 10: DURATION OF PLAY

- A. The duration of the game will be 60 minutes maximum; two 30 minute periods/halves.
- B. The horn indicates the end of time in each half and overtime period. After halftime, which may not exceed 10 minutes, teams will change ends.

Guidance: The length of the halves may be reduced for competition that is not an official FIL event. The umpires and captains/coaches must agree on the length of the halves.

- C. The umpire's whistle starts and stops play. When the whistle sounds to stop play, all players, except for the goalkeeper when she is inside the goal circle, must **'stand'** and may not move until the whistle sounds to resume play. The game begins at the sound of the umpire's whistle at the opening draw. The game is restarted with a draw after a goal is scored, following a team time out, and following halftime intermission. In some instances, the game begins with a throw or a free position.
- D. The clock is stopped on the umpire's whistle and goal signal when a goal is scored, and at every whistle that stops play during the last two minutes of each half. When play is stopped prior to the last two minutes, the timer will stop the clock when it reaches two minutes if play has not resumed
- I. Exception: Event coordinators, coaches/captains and umpires may mutually agree not to stop the clock after goals if one team is ahead by 12 or more goals. If the goal difference becomes less than 12 goals, the stop clock will be reinstated. The clock will always stop on every whistle that stops play within the last two minutes of each half.

RULE 10 / DURATION OF PLAY

- E. Play should be continuous, but at the discretion of the umpire, a time out may be taken for unusual circumstances including: a broken crosse, an animal on the field, a lost ball or a ball that has gone too far out of bounds, an inadvertent whistle, delaying the game or spectator interference. The umpires must also stop play for illness, injuries and accidents, to issue warning cards, to inspect a crosse and to remove illegal substitutes. In some instances the clock will stop to reset a draw.
- F. If weather conditions or any other extenuating circumstances make play dangerous, the umpires will suspend the game after consultation with the captains/coaches. The umpires' decisions are final.

Guidance: Umpires must be cautious about deciding to continue a game when weather conditions become a factor. Safety must be the primary concern. Secondary considerations include the team's travel time and expense.

***FIL Lightning Safety Policy** – When an umpire, athletic trainer or other official staff personnel hears thunder or sees lightning, activate a safety plan. Game personnel should identify a safe shelter before the start of an event or game. At ANY sign of lightning, the field and site must be cleared. Play should not resume until at least 30 minutes after the last thunder/lightning strike.*

- G. A game is considered legal and complete if 80% of the playing time has elapsed. Eighty percent of a 60 minute game is 48 minutes. If an interrupted game (one in which less than 80% of the game has been played) is continued on the same day, it will be restarted from the point of interruption. A suspended game that is replayed on another day must be replayed from the beginning.

Guidance: To accommodate the time constraints of a tournament, a suspended game that is replayed on another day may be restarted from the point of interruption.

- H. Each team may request two 90 second team time outs per game, after a goal has been scored. A coach may request the time out through the scorer's table, or the captain on the field may make the request directly to the nearest umpire. Only one team will be granted a team time out

RULE 10 / DURATION OF PLAY

after a goal. Team time outs not used during regulation game time are permitted during overtime.

***Guidance:** When a team time out is requested, the 90 seconds will begin at the sound of the horn or the umpire's whistle. The timer will advise the umpires and teams when 30 seconds remain. Teams must be on the field and ready to resume play at the 90 second horn/whistle. If a team is not ready to play, a minor foul free position will be awarded to the opponents at the center line.*

- I. It is recommended that a horn be used to end each half and team time out. When a horn is not available, the umpire's whistle (three short blasts) will indicate the end of each half.

RULE 11: SUBSTITUTION

- A. Each team may substitute an unlimited number of players at any time during the play, including overtime, after every goal, after a team time out and at halftime. All substitutions must be made through the substitution area, and during play, all players, including the goalkeeper, must come off the field and exit between the cones/markers before a substitute may go on to the field. No other players or coaches are permitted in the substitution area except those players waiting to immediately enter the game. When an illegal substitution occurs, the scorer/timer will immediately notify the nearest umpire.

***Guidance:** Players substituting after a goal is scored may immediately enter the game and do not have to wait for the teammates they are replacing to come completely off the field. All players must enter and exit the field through the substitution area. Umpires should count the players on the field before restarting play.*

- I. An extra player, an ineligible suspended player or an illegal player are all illegal substitutes. Once the game starts, a player whose name and number are listed incorrectly on, or have been omitted

RULE 11 / SUBSTITUTION

- from, the team score sheet, may enter the game when the correction is made. Her team will be penalized for an illegal substitution.
2. If the attacking team substitutes illegally, the umpire will stop play immediately and award free position to the opponents.
 - a. If the illegal substitute is discovered on the attacking team after a goal is scored and before the next draw, the goal will not count. The illegal player will be removed, players must stand, and the opposing goalkeeper will be awarded a free position inside the goal circle. (Rule 19.A.17)
 3. If the defending team substitutes illegally and the ball is in the midfield, between the restraining lines, the umpire will stop play immediately. If the ball is below/goal side of the restraining line, the umpire will stop play following a missed shot or a change of possession. If the attack shoots and scores, play will resume at center with a draw.
 4. When an illegal substitution occurs, the umpire will call time out and remove the illegal player from the field and award a minor foul free position to the opponents at or near the spot of the ball. If players from both teams substitute illegally, a throw will be taken to resume play.
 5. If a player on the field is both an illegal substitute and offside, remove the player and penalize the offside to resume play. (Rule 18.B.7)
- B. When a player receives a yellow card, a yellow/red card together, a straight red card, or green/red card together, the player must leave the field for a timed penalty suspension. During the suspension her team must play with one less player below/goal side of the restraining lines. Carded players will serve suspensions in their team bench area.
1. If a field player receives a yellow card or green/red card together, the player or a substitute may re-enter the game when the timed penalty suspension expires.

RULE 11 / SUBSTITUTION

- a. If the goalkeeper receives a yellow card, and her team has a 'second dressed' goalkeeper, the second goalkeeper will replace the suspended goalkeeper. If the suspended goalkeeper is her team's 'only dressed' goalkeeper, she may remain in the game. The teammate who is below/goal side of the restraining line and nearest to her team's substitution area must leave the field to begin the two minute penalty suspension.
- b. To resume play, the goalkeeper will stand 4 m behind the attack player awarded the free position, and the goal circle will remain empty. Once play resumes, the field player who was removed from the field to begin the timed penalty suspension may re-enter the game as long as her team continues to play short for the duration of the goalkeeper's penalty suspension. (Rule 22.B.2)
2. If a field player receives a yellow/red card together or a straight red card, she may not return to the game. Only an eligible substitute may enter the game when the timed penalty suspension expires.
 - a. If a goalkeeper receives a yellow/red or a straight red card, she is suspended for the remainder of game. If her team has a 'second dressed' goalkeeper, she will replace the suspended goalkeeper. If the suspended goalkeeper is her team's 'only dressed' goalkeeper, a two minute time out will be taken to enable a teammate to put on protective equipment. If that player is on the field a substitute will take her place. The teammate who is below/goal side of the restraining line and nearest to her team's substitution area must leave the field to begin the two minute penalty suspension. Play will resume according to Rule 11.B.1.b. above. (Rule 22.B.3)
3. If a player or substitute enters the game before the time of the suspension expires, the player or her team must reserve the entire timed suspension.

RULE 11 / SUBSTITUTION

4. If a player is suspended with less than 2 minutes remaining in the half for a yellow card, (5 minutes for yellow/red or green/red card, or 10 minutes for a straight red card), the suspension will carry over into the second half and overtime when played.
- C. Time out is not taken for substitution except in the event of illness, accident or injury. An incapacitated field player is allowed up to two (2) minutes recovery time, and an incapacitated goalkeeper is allowed up to five (5) minutes recovery time. No player is allowed to remain on the field with an open wound or blood-saturated clothing or equipment. (Appendix C: FIL Policies Regarding Blood)

***Guidance:** The timer will time the 2 or 5 minutes recovery time. During the recovery time, players may drop their crosses and go to the sideline for water; however, coaching is not permitted during an injury time out unless a goal has been scored or a team chooses to use one of their team time outs. Umpires must supervise the team bench areas during injury time outs. Coaching during an injury time out is a major foul. (Rule 20.A.21)*

- I. When a substitution is made during an injury time out, no other substitutions are permitted. The substitute must assume the same location as the injured player she is replacing; no advantage will be gained. Unless the injury substitution occurs after a goal or if the injured player is her team's 'only dressed' goalkeeper, players may not exchange positions on the field during an injury time out until play resumes.
 - a. If the injured goalkeeper's substitute is a player on the field, she may leave the game to put on protective equipment and replace the injured goalkeeper. A player from the bench may replace that field player.

***Guidance:** When a player is removed for an injury or for an illegal uniform or equipment, and the game is restarted without a substitute taking her place, the returning player or her substitute must re-enter the game through the substitution area only.*

2. Following an injury time out the game will be restarted according to Rule 12.C.

RULE 12: START & RESTART THE GAME

- A. Each half of the game and overtime period, and after each goal, the game is started with a Draw except when a free position or throw is awarded at the center line. During the draw, five players maximum from each team may be between the restraining lines, the centers and four other players from each team. All other players must be below either restraining line. Players must not step on or over the center circle line or the restraining lines until the whistle sounds to start play. Both goalkeepers must remain below/goal side of their team's defensive restraining line for the draw. (Rule 19.A.10 & 11)

Guidance: When the game starts or restarts with a free position or a throw at the center line rather than with a draw, players will take positions as they would for the draw and must stand until the whistle sounds to resume play.

1. To draw, two opponents stand with one foot **'toeing the center line'**. Their crosses are held in the air above hip level, wood/plastic to wood/plastic, parallel to and above the center line. Both the head and shaft must lie along the vertical plane of the center line. The crosses will be held back to back, the right sidewall is down, so that each player's crosse is between the ball and the goal she is defending. A player's top hand may not contact the throat, the pocket or the sidewall of her crosse. (Rule 19.A.1)

Guidance: The right sidewall of a molded head crosse refers to the right side of the crosse when a player holds the crosse vertically with the open pocket facing her. The right sidewall of a wooden crosse is the wooden side.

When setting the draw, umpires must be aware of height differences between centers and position the height of the crosses so that neither player gains an advantage.

2. The umpire places the ball between the crosses. Once the crosses are set, the umpire says, "ready" before moving backwards out of the center circle. At the word "ready", players taking the draw must remain motionless (except for moving their heads) until the whistle sounds. At the whistle, both players must immediately draw

RULE 12 / START & RESTART THE GAME

their crosses up and away from one another. The flight of the ball must go higher than the heads of both players taking the draw.

Guidance: Umpires should vary the time interval between the word 'Ready' and the whistle. The umpire administering the draw should plan a route out of the center circle so that she does not interfere with players moving in to play the ball.

- a. When an illegal draw occurs, the opponent will be awarded minor foul free position at the center line. (Rules 19.A.9.d.1)
 - b. If both players draw illegally, or it cannot be determined why the draw was illegal, or an umpire determines that the draw was unsuccessful because it was not set correctly, the umpire will call time out to reset the draw. Exception: When agreed prior to the game/event, the clock will continue to run after goals if one team is leading by 12 or more goals.
- B. Players outside the center circle and below the restraining lines are not required to stand during the draw. Players may hang their crosses into the center circle and over the restraining lines, but their crosses may not touch the ground and their feet must not touch the center circle line or the restraining lines. (Rule 19.A.10)

Guidance: The umpire administering the draw is responsible for fouls committed by the players taking the draw. The other umpires are responsible for fouls committed during the draw by all other players. Umpires must watch for players around the center circle using their bodies and/or crosses to hold or detain their opponents.

Entering the center circle or moving above the restraining lines before the whistle is a minor foul and will be called if the player or her team gains a clear advantage because of the violation. To restart play, a free position for an illegal draw will be set at the center line and all players must stand.

- C. If the game must be stopped because of an accident, injury, illness, interference, inadvertent whistle or any other circumstance related or unrelated to the ball, the game will be restarted in one of three ways.
- I. If a foul occurred, a free position will be awarded at a spot determined by the umpire in accordance with the rules.

RULE 12 / START & RESTART THE GAME

Play must not resume within 11 m of the center of the goal line or within 4 m of the boundary.

2. If a foul did not occur, the ball will be awarded to the player who was in possession of it when play was stopped, at least 11 m of the center of the goal line and 4 m inside the boundary. The opponent must give the ball carrier at least 1m of clear space with her stick and feet.
3. If neither team had possession of the ball when play was stopped, a throw will be taken at or near the incident and /or the spot of the ball when play was stopped, at least 15 m from the center of the goal line, 4 m inside the boundary and 4 m away from the restraining lines.

RULE 13: SCORING

- A. The team scoring the greater number of goals wins. If the scores are equal, the result is a tie. When a winner must be determined, overtime procedures are in Rule 24.F.
- B. A goal is scored when the whole ball passes completely over the whole goal line; between the goal posts and under the crossbar from in front; the ball having been propelled from an attack player's legal crosse; from a defender's crosse; or off a defender's body.

Guidance: If a player is discovered wearing jewelry or not wearing a mouth guard immediately after a goal is scored, the goal counts. To resume play, a minor foul free position is taken at the center line. (Rule 19.A.13)

- C. A goal is **NOT** scored when:
 1. The ball is put in the goal by a non-player, including an umpire.
 2. The ball comes off the person/body of an attack player.
 3. The ball enters the goal after a whistle is blown or the horn has sounded.
 4. The attack shooter steps on or over the goal circle line or if any other attack player enters the goal circle.

RULE 13 / SCORING

5. The goalkeeper is inside the goal circle, and she or her crosse are interfered with in any way by an attack player.
6. The umpire rules a shot or follow-through as dangerous.
7. The ball enters the goal while the attacking team has an illegal player on the field.
8. The ball enters the goal from an attack player's illegal crosse.
9. The player who shot the goal adjusts her crosse after an umpire's request for a pocket inspection; the crosse will be removed from the game.
10. The ball is shot or otherwise put into the goal by the attacking team's goalkeeper.
11. The ball enters the goal when the attacking team has more than seven players below/goal side of the restraining line.

RULE 14: OUT OF BOUNDS

- A. When the ball goes out of bounds, the umpire will blow the whistle to stop play and players must stand. Except in the case of a shot or deflected shot on goal, when a player **'in possession of the ball'** carries, propels, or is the last to touch a loose ball before it goes out of bounds, the opponents will be awarded the ball when play resumes. Players may not take an active part in the game when their foot/feet are out of bounds. During the game players may not run out of bounds and re-enter to a more advantageous position. (Rule 23: Definitions)

With the exceptions in Rules 14.B.3, 14.C.1, and 14.C.2 when a ball goes out of bounds, it is a simple change of possession to resume play, not a foul.

Guidance: To avoid a 'pick' set on the boundary by an opponent, a player runs out of bounds around the pick and returns to the field in a position that allows her to check the ball from the ball carrier's crosse. ILLEGAL: the ball carrier maintains possession 4 m inside the boundary.

RULE 14 / OUT OF BOUNDS

A player chasing a ball toward the boundary is able to stop the ball from going out of bounds with her crosse, and as the ball comes to rest, her momentum takes her out of bounds. The player stops, turns and steps fully back on to the field, picks up the ball and continues with play, LEGAL

If a player is offside when the ball goes out of bounds, the minor offside foul will be penalized to resume play. (Rule 18.B.6)

- B.** When a player is in possession of the ball and steps on or over the boundary line, or any part of her body or crosse touches the ground on or outside the boundary, the ball is out of bounds, and the player will lose possession of it.
1. A player is in possession of the ball when the ball is in her crosse, and she can perform any of the normal functions of control such as cradling, carrying, passing or shooting the ball.
 2. A player in possession of the ball may hold her crosse outside the boundary as long as her foot/feet do not touch the boundary line and still be considered in bounds. If an opponent, whose feet are in bounds, legally checks the player's crosse and causes the ball to fall to the ground outside the boundary, possession will be awarded to the opponent when play resumes.
 3. When an opponent illegally causes a player in possession of the ball to go out of bounds, the ball carrier will maintain possession of the ball when play resumes. The opponent will be penalized for a major foul. (Rule 20.A.6)
- C.** When a loose ball touches the boundary line or the ground outside the boundary line, the ball is out of bounds. The player/team that last touched the ball before it went out of bounds will lose possession of it, unless it was a shot or a deflected shot on goal.
1. If a player deliberately pushes, flicks or bats the ball into an opponent's feet or body to cause the ball to go out of bounds the opponent will be awarded a major foul free position 4 m inside the boundary. (Rule 20.A.10)
 2. It is a minor foul when a player deliberately/with intention uses her foot/feet or any other part of her body to stop the ball from going out of bounds. (Rule 19.A.5)

RULE 14 / OUT OF BOUNDS

- D. To resume play when the ball has gone out of bounds:
1. The opponent nearest the ball will place the ball in her crosse and stand 4 m inside the boundary from the spot where the ball went out of bounds. If the goalkeeper is inside the goal circle and the nearest player to the ball when it crosses the boundary, she will be awarded the ball inside the goal circle to restart play.
 2. An umpire may request other player/s to move if they were directly involved in the play or in the immediate vicinity of the spot where the ball went out of bounds. Players must maintain the same relative field position/relationship to the player with the ball as they had when the whistle sounded to stop play.
 3. Opponents must give the player awarded the ball at least 1 m of free/clear space (stick, body and feet). All other players must stand and the game will resume at the whistle.
- E. When a shot or deflected shot on goal goes out of bounds, the player nearest to the ball when it crosses the boundary will place the ball in her crosse and stand 4 m inside the boundary line from the spot where the ball went out of bounds. If two players are equidistant from the ball when it goes out of bounds, a throw will be taken to restart play. The throw will be set 15 m from the center of the goal line and 4 m inside the boundary. When the goalkeeper is inside the goal circle and the nearest player to the ball when it crosses the boundary, she will be awarded the ball inside the goal circle to restart play.
1. A deflected shot is one that goes directly out of bounds after hitting the goal post or the goalkeeper's crosse or body. A deflection occurs when a player merely touches the ball with her crosse or body and does not gain any distinct/clear advantage or control of the ball.
 2. A shot or deflected shot remains a shot until the ball goes out of bounds or comes to rest on the playing field, a player gains possession of the ball, or a player otherwise causes the ball to go out of bounds.

RULE 14 / OUT OF BOUNDS

3. When a shot or deflected shot goes out of bounds off an umpire's body, a throw will be taken to resume play. When a ball rebounds /deflects off an umpire's body and stays in bounds, play will continue. (Rule 15.B)

4. It is the umpire's responsibility to determine if a thrown ball is a shot, and the umpire will immediately call out the word "shot".

***Guidance:** A shot rebounds from the goal post and goes out of bounds below/goal side of the restraining line. A player, who is above/behind and may not cross the restraining line, is the player nearest to the ball when it crosses the sideline. To resume play, the player above/behind the restraining line will be awarded possession of the ball. In this instance, move the ball, not the player.*

A shot that rebounds off the goal post, the goalkeeper's crosse or body and then directly out of bounds off any field player's crosse/body or an umpire's body, is considered a deflected shot.

Umpires must differentiate between a shot/deflected shot that goes out of bounds off a player's body, and a ball that is dangerously propelled at and hits a defender who is legally marking her opponent in front of goal. Dangerous propelling must be carded.

A shot misses the goal and comes to rest on the ground. A player attempts to pick up the ball and the ball goes out of bounds. To resume play, the nearest opponent will be awarded the ball.

Following a shot, a player in Red tries to pick up the ball as it rolls toward the boundary and out of bounds. The player in Red will be awarded the ball to resume play.

*A player in Blue attempts a pass to a teammate. The teammate misses the ball and plays the ball off her foot to prevent the ball from going out of bounds. **ILLEGAL:** award the opponents a minor foul free position for a deliberate body ball. (Rule 19.A.5)*

- F. When the ball goes directly out of bounds from a legal draw, a throw will be taken 4 m inside the boundary, 4 m away from the restraining line, and at least 15 m from the center of the goal line. (Rule 15.B.10)
- G. When the ball goes out of bounds over an end line boundary, play will not resume within 4 m of the end line or 11 m of the center of the goal line. (Rule 1.D.1)

RULE 15: THROW

- A. Two opposing players stand with their feet and crosses at least one meter apart. Each player stands nearer the goal she is defending and faces in toward the playing area. The umpire stands between 6 and 8 meters from the players and simultaneously blows the whistle and tosses the ball in a short high arc towards the players so they can catch or otherwise play the ball as they move in toward the game.

A throw is administered at or near the incident and/or the spot of the ball when play was stopped, except that all throws must be taken at least 15 m from the center of the goal line, 4 m inside the boundary and 4 m away from the restraining lines. No other player may be within 4 m of the two players taking the throw.

If the throw is inaccurate or is not touched by either player, it must be repeated.

- B. A throw is taken when:
1. The ball goes into the goal off of a non-player, including an umpire. The two nearest opponents will be awarded a throw on the goal line extension at least 15 m from the center of the goal line. (Rule 13.C)
 2. The ball goes out of bounds following a shot or a deflected shot, and two opponents are equally distant (stick or feet) from the ball where it crosses the boundary. (Rule 14.E)
 3. Following a shot, the ball deflects out of bounds off an umpire's body. (Rule 14.E)
 4. It cannot be determined which team caused the ball to go out of bounds. (Rule 12.C)
 5. There is an incident unrelated to the ball and neither team has possession of the ball. (Rule 12.C)
 6. The game is restarted after an incident related to the ball, neither team has committed a foul, and neither team has possession of the ball. (Rule 12.C)
 7. The ball lodges in the clothing of a field player or umpire.
 8. Two opponents foul simultaneously (major/major or minor/minor) (Rule 16.B.5)

RULE 15 / THROW

Guidance: If fouls are not equivalent, i.e. major and minor, the major foul will be penalized. (Rule 16)

9. The attacking team fouls, major or minor, during a scoring play/raised advantage flag, a throw will be taken beyond 15 m, level with the goal line extension. (Rule 21.C.4)
10. The ball goes directly out of bounds from a draw. The throw will be awarded 4 m inside the boundary from where it went out of bounds and 4 m away from the restraining line. (Rule 14.F)

RULE 16: CONDUCT OF PLAY

- A. The ball is 'dead' whenever an umpire blows the whistle to stop play. All players, except the goalkeeper or her deputy while inside the goal circle, must 'stand' and may not move until play resumes unless they are directed to do so by the umpire. If a player moves after the whistle, the umpire must direct the player to move back to her original position.

Guidance: Players who repeatedly fail to stand when the whistle sounds to stop play, may be carded for delaying the game.

- B. Violation of any rule is a foul. The penalty for a foul is a free position. A free position must not be taken within 11 m of the center of the goal line, within 4 m of the boundary, and, in some instances, within 4 m of the restraining line. **Exception:** The goalkeeper or a deputy may be awarded a free position inside the goal circle.
1. The umpire indicates where the player taking the free position will stand.
 2. No other player's body or crosse is allowed within 4 m of the player awarded the free position. Any player who is within 4 m must move away to a position indicated by the umpire.
 3. The player who committed the foul will move 4 m away from the player taking the free position, except for the goalkeeper when she commits a goal circle foul or a minor foul while she is completely or partially inside her goal circle. (Rules 17.C.2 & 19.B.2)

RULE 16 / CONDUCT OF PLAY

- a. For minor foul penalties, the player who committed the foul will move 4 m away in the direction from which she approached her opponent before committing the foul. This applies to the goalkeeper if she is completely (both feet) outside the goal circle. (Rule 19.B)
 - b. For major foul penalties, the player who committed the foul will stand 4 m directly behind the player who is awarded the free position. This applies to the goalkeeper, whether she is inside or outside the goal circle when she fouled. (Rule 20.B)
4. To resume play, the player taking a free position places the ball in her crosse, and at the umpire's whistle, she may run, shoot or pass.
Guidance: Since the clock is running, umpires must set up free positions and resume play quickly. Time out may occasionally be called to prevent undue delays.
5. If two opposing players foul simultaneously and the fouls are equivalent (minor/minor or major/major), a throw is taken. If the fouls are not equivalent, major and minor, the team committing the major foul is penalized. Exception: When the attack commits any major or minor foul during a raised advantage flag/scoring play, the fouls will be treated as equivalent/offsetting fouls and a throw will be awarded. (Rules 15.B.9 and 21.C.4)
- C. HELD WHISTLE: An umpire may refrain from enforcing any rule when it would penalize the non-offending team. When a player is fouled but is able to maintain quality possession of the ball, the umpire will indicate that she has seen the foul by extending a straight arm in the direction that player is attacking.
Guidance: Mere possession of the ball is not necessarily an advantage. Umpires must not hold whistle to a player's disadvantage.

RULE 17: GOAL CIRCLE RULES AND PENALTIES

A. Goal Circle Rules

1. Only one player, either the goalkeeper or her deputy, an unprotected field player, is allowed to be inside the goal circle at any one time. A ball resting on any part of the goal circle line belongs to the goalkeeper or the deputy.
2. With the following exceptions, no other players are allowed to enter or have their feet, body or crosse on or over the goal circle line at any time.
 - a. On a shot, the attack shooter may follow through with her crosse over the goal circle line, but her feet must not touch or cross over the goal circle line. The attacks shooting motion must be initiated from outside the goal circle; therefore, the shooter's crosse must be outside the goal circle when she receives a pass from a teammate to attempt or complete a shot.
 - b. On a shot, only the player/s directly marking/defending the attack shooter may reach into the goal circle with their crosse/s to block the shot or check the shooter's crosse. The defender/s feet must not touch or cross over the goal circle line.
3. While inside the goal circle, the goalkeeper:
 - a. Must move the ball out of the goal circle within 10 seconds after the ball has entered the goal circle.
 - b. May stop the ball with her hand, body and/or her crosse. If she catches the ball, she must put the ball in her crosse and proceed with the game.
 - c. Must remove a ball lodged in the goal netting, her clothing or pads, and place it in her crosse and proceed with the game.

Guidance: The Umpire may signal time out to assist the goalkeeper with dislodging the ball from her clothing, equipment or the goal netting. The 10 second count will begin once play is restarted.

RULE 17 / GOAL CIRCLE RULES & PENALTIES

- d. May reach outside the goal circle with her crosse and bring the ball back into the goal circle provided no part of her body is **'grounded'** outside the goal circle. (Rule 23: Definitions)
Guidance: From inside the goal circle, the goalkeeper or a deputy may, with one or both feet, step or stand on the goal circle line. As long as her feet are touching any part of the goal circle line, she is considered to be inside the goal circle.

In the process of bringing the ball back into the goal circle, it is a minor foul if the goalkeeper covers the ball with her crosse, and in doing so, prevents an opponent from making a play on the ball. (Rule 19.A.2)

4. The Deputy:
- May only enter or remain in the goal circle when her team has possession of the ball.
 - Must immediately leave the goal circle when her team loses possession of the ball. A player/team is not in possession of a loose ball that is outside the goal circle, on the ground or in the air.
 - May enter the goal circle to play a rolling or low bouncing ball; however, a deputy/may never enter the goal circle to defend any shot; including a bounce shot.
 - Must move the ball out of the goal circle within 10 seconds after the ball has entered the goal circle.
 - While inside the goal circle, must remove a ball lodged in the goal netting or her crosse, place it in her crosse and proceed with the game.
5. Once a goalkeeper or her deputy moves the ball out of the goal circle within 10 seconds, the ball must not return to her team's goal circle until the ball has been played. **'Played'** refers to an action whereby the ball leaves a player's crosse and is touched by another player, or her crosse is checked crosse to crosse by an opponent. (Rule 23: Definitions)
- If the goalkeeper passes the ball from inside the goal circle to another player, the ball has been played.

RULE 17 /GOAL CIRCLE RULES & PENALTIES

- b. If the goalkeeper moves out of the goal circle with the ball in her crosse, she may not return the ball to her goal circle until it has been played.
- c. If the goalkeeper gains possession of the ball outside the goal circle, she may return the ball to the goal circle for one 10 second count.

***Guidance:** The goalkeeper is inside the goal circle when she saves a shot on goal; the 10 seconds count begins. While she is looking for an open teammate, her crosse with the ball in it is hanging outside the goal circle. As the 10 seconds count is about to expire, an opponent legally checks the goalkeeper's crosse but is unsuccessful in dislodging the ball. The goalkeeper quickly pulls her crosse, with the ball in it, back into the goal circle and passes the ball to an open teammate. **LEGAL:** the ball was outside the goal circle when the goalkeeper's crosse was played, checked crosse to crosse by an opponent.*

6. When both feet of the goalkeeper or a deputy are completely outside the goal circle:
 - a. She loses all of her goalkeeping privileges.

***Guidance:** When the goalkeeper is completely outside of her goal circle, she may be called for obstructing the free space to goal.*
 - b. She may only re-enter the goal circle without the ball.
 - c. She may throw the ball into the goal circle and then follow it into the goal circle.
 - d. She must return to the goal circle to play the ball that is inside the goal circle.

B. Goal Circle Fouls

I. Field players:

- a. On a shot, the attack shooter and the defender/s immediately marking the shooter must not step on or over the goal circle line. No other field players are allowed to enter or have their feet, body or crosse on or over the goal circle line at any time.
- b. The shooter must not receive a pass or initiate a shot when her crosse is inside the goal circle.

RULE 17 /GOAL CIRCLE RULES & PENALTIES

- c. During and immediately following the shot, the attack shooter must not illegally interfere with the goalkeeper or defender/s immediately marking her. Defenders must not illegally interfere with the attack shooter.

***Guidance:** Defenders who have legally established their position near the goal circle before the shot must not be penalized for illegal contact caused by the attack shooter or one of her teammates.*

Defenders must not push the shooter into the goal circle or in any other way illegally interfere with the shooter or shot.

- d. A deputy field player must not illegally enter or remain in the goal circle.
2. The goalkeeper and her deputy must not:
- a. Allow the ball to remain inside the goal circle for longer than 10 seconds. Once the goalkeeper or a deputy moves the ball out of the goal circle, her team must not return the ball to their goal circle until it has been played by another player.
***Guidance:** The umpire will use a visible, hand chopping motion to count each second that the ball remains in the goal circle. The umpire will count from 1 to 10, and when necessary, will count the last 5 seconds out loud.*
- b. Reach outside the goal circle with any part of her body to play an aerial or ground ball while she is inside the goal circle. (Rules 17.B.2.b & 20.A.19)
- c. Rake the ball into her goal circle when any part of her body is completely grounded outside the goal circle. (Rule 19.A.2)
- d. Throw any of her equipment to another player.
- e. When outside the goal circle, step on the goal circle line or back into the goal circle if she has possession of the ball.
***Guidance:** The goalkeeper straddles the goal circle line to pick up a ground ball and steps back into the goal circle. Illegal: the goalkeeper was 'grounded'. To resume play, the goalkeeper remains at the spot of the foul (inside the goal circle), and the attack is awarded a free position for the goal circle foul at 15 m on the goal line extended.*

RULE 17 /GOAL CIRCLE RULES & PENALTIES

C. Penalties for Goal Circle Fouls

1. With two exceptions below, when the defense commits a goal circle foul, the free position is taken 15 m from the center of the goal circle, to the side of the goal nearest the violation, and level with the goal line. Unless it is the goalkeeper, the player who fouled, will move to the 11 m mark on the goal line extended.
 - a. Whenever the goalkeeper commits a goal circle foul, she remains at the spot of the foul, and if she was in or partially inside the goal circle, she remains inside the goal circle for the free position.
 - b. When the deputy is illegally in the goal circle, it is a major foul and the umpire must stop play immediately. The free position will be awarded to the attack player who is nearest to the center 11 m hash mark when play stopped. The illegal deputy will move 4 m behind the attack player with the ball, and the marking area will be cleared. The goalkeeper must NOT return to the goal circle until play resumes at the whistle.
2. When the attack commits a goal circle foul, the goalkeeper or a deputy will take the free position inside the goal circle. If a goal was scored, the goal will not count. Before play resumes, all players must move 4 m away from the goal circle.

***Guidance:** If the goalkeeper is completely outside the goal circle when the attack commits a goal circle foul, the defense player closest to the goal circle, which may or may not be the goalkeeper, shall take the free position inside the goal circle.*

*An attack player in front of the goal receives a pass from a teammate who is behind goal. The attack player's crosse is inside the goal circle when she receives the pass; she shoots and scores. **Illegal:** no goal, the attack is penalized for a goal circle violation. An attack shooter must receive a pass and initiate her shot from outside the goal circle.*

4. When a major foul must be carded during goal circle play, the game will resume according to Rule 20.B & 22.B. During a scoring play, the game will resume according to Rule 21.D.5.

RULE 18: RESTRAINING LINE RULES AND PENALTIES

A. A team must not:

1. Have more than seven attack players below/goal side of the restraining line in their offensive/attacking end of the field.
2. Have more than eight defense players below/goal side of the restraining line in their defensive end of the field. One of these eight players is usually, but not necessarily the goalkeeper.

***Guidance:** If a team chooses to play without a goalkeeper, they may have eight field players in their defensive end. However, an unprotected field player/deputy may never enter the goal circle to defend a shot on goal. (Rule 17.A.4.c)*

3. Players may exchange places during play, but a player must have both feet above/behind the restraining line before a teammate may move below/goal side of the restraining line. An illegal exchange is an immediate whistle.

***Guidance:** The goalkeeper in Blue saves a shot and is looking to clear the ball to a teammate who is above/behind the restraining line. The teammate in Blue cuts below/goal side of the restraining line to receive the pass before another one of her teammates has moved above/behind the restraining line to make the exchange legal; the team in Blue is offside.*

4. Any part of a player's foot that is on or over the restraining line is a violation. Players may reach over the line with their sticks to play the ball as long as their foot/feet are not on or over the line.

***Guidance:** Umpires must watch for pushing, empty crosse checks, and covering when players are trying to win possession of the ball at the restraining line.*

5. The restraining line rule remains in effect at all times, for the entire game.

***Guidance:** The team in Blue is playing with one less player because one of their players has received a personal misconduct warning card. The team in Blue must play short below/goal side of the restraining lines at both ends of the field.*

RULE 18 / RESTRAINING LINE RULE & PENALTIES

If the team in Blue is playing with less than 12 players for any other reason, they may choose to play with one less player in the midfield between the restraining lines or below/goal side of the restraining lines.

6. Violation of the restraining line is a minor foul. Offside is an immediate whistle unless the defense is offside when the attack is on a scoring play within 15 m of goal. (Rules 21.A & 21.B)

Guidance: Umpires indicate a restraining line violation by raising an arm straight over their head. If there is an inadvertent whistle for an offside violation and no other foul has occurred, the game will resume according to Rule 12.C. The player in possession of the ball retains possession of it, or if no player has possession of the ball, a throw will be awarded.

B. Penalties

1. If the attack is offside and a goal is scored, the goal will not count. (Rule 13.C.11)
2. When a team is offside, the penalties for both attack and defense offside are the same, and the free position is set relative to the spot of the ball when offside is called.
 - a. If the ball is in the 15 m fan or anywhere inside the goal circle when the violation occurs, the opponent nearest to the top center of the 15 m fan will be awarded the free position. The nearest player on the team that was offside will move 4 m to the side of the player awarded the ball. The offside player or the teammate nearest to the restraining line will move back onside.
 - b. If the ball is outside the 15 m fan or below the goal line extended when the offside violation occurs, the free position will be awarded to the nearest opponent at the spot of the ball; at least 11 m from the center of the goal line and 4 m inside the boundary. The closest player on the offside team will move 4 m to the side of the player awarded the ball. The offside player or the teammate nearest the restraining line will move back onside.

RULE 18 / RESTRAINING LINE RULE & PENALTIES

Guidance: The side to which a player must move for the free position is determined by her field position and relationship to the opponent awarded the ball when the offside was called.

- c. Whenever an offside violation is penalized, and the goalkeeper is outside the goal circle and has not fouled, the goalkeeper may return to the goal circle for the free position.
3. If players from both teams are offside, the offside players will move back onside and a throw will be taken at or near the spot of the ball when play stopped, at least 15 m from the center of the goal line, 4 m from the boundary and 4 m from the restraining line. (Rule 15.B)

Guidance: The goalkeeper checks an attack player's arm as she attempts a shot on goal; the ball goes wide and out of bounds. The trail umpire immediately blows her whistle because an attack and a defender are both offside. To resume play, the offside players will move back onside, and the major foul will be penalized. The attack free position will be awarded on the nearest 11m hash mark in line with the foul, and the goalkeeper must move 4 m behind. The goal cage will remain empty. (Rule 16.B.5)

- a. If the defense is offside, and play ends with a major foul by the attack (no advantage flag/scoring play), penalize the major foul to resume play. If play ended with a minor foul by the attack, a throw will be awarded beyond 15 meters level with the goal line extended.
4. If the defense is offside during an attack scoring play, and the scoring play ends with a major or minor foul by the attack, the fouls are offsetting. To resume play, the offside player will move back onside and a throw will be awarded beyond 15 m level with the goal line extended. (Rules 15.B.9 & 21.C.4)
5. When play ends with an out of bounds call (no foul) and a player is offside, penalize the offside to resume play.
6. When an ineligible/illegal player is both on the field and offside remove the player and penalize the offside to resume play.

RULE 19: MINOR FOUL RULES AND PENALTIES

A. Minor Foul Rules

1. During the draw and at all other times during the game, a player's top hand may not contact the throat of the crosse, or any part of sidewall or pocket.

***Guidance:** For one piece crosses, the throat begins where the head starts to flare from the shaft.*

2. A player must not cover a ground ball with her crosse or any part of her body when it prevents an opponent from making a legal play on the ball.

***Guidance:** A player may quickly place her crosse between an opponent's crosse and the ball to push or flick the ball to an open space or teammate.*

3. A player must not guard her crosse with her arm. If one hand is removed from the shaft of the crosse, an elbow or free arm may not be used to ward off an opponent deliberately or otherwise, with or without contact.

***Guidance:** Guarding the crosse should not be confused with the natural movement of the free arm when a player is running and holding the crosse with one hand.*

4. A field player must not touch the ball with her hand or use her thumb or body to keep the ball in her crosse unless she is a goalkeeper or deputy inside the goal circle. (Rule 17.A.3.b)

5. A player must not allow any part of her body to deliberately impede, accelerate or change the direction of the ball.

***Guidance:** "Deliberate" implies intent and intent is determined by players' actions on the field. Ball contact from an unexpected deflection may not be deliberate.*

It is a major foul if the goalkeeper blatantly attempts to stop a shot on goal by playing the ball off her body while she is completely outside the goal circle. (Rule 20.A.19)

RULE 19 / MINOR FOULS & PENALTIES

6. A player must not check/tackle an opponent's empty crosse while the opponent is trying to gain possession of the ball. This rule applies when an opponent is attempting to play a ground ball or could have received a pass.

***Guidance:** A player need not be in possession or control of the ball before her crosse may be checked. When a player's crosse is in contact with the ball, an opponent may check her crosse. A check is legal if it is simultaneous with the ball contacting an opponent's crosse.*

7. A player must not throw her crosse under any circumstances.
8. A player must not take part in the game if she is not holding her own legal crosse.

***Guidance:** A player's own legal crosse is one that meets manufacturer's specifications in Rule 25 and has been checked prior to the game. A field player may not score a goal with a crosse that does not meet field crosse specifications.*

9. A player must not draw illegally. An illegal draw occurs when:
 - a. A player moves after the umpire says, "Ready", or draws before the umpire's whistle.

***Guidance:** Except for moving their heads to watch the umpire, the centers' bodies and sticks must remain motionless after the word "Ready". The umpire administering the draw must watch for centers laying back the head of their crosse before the whistle.*

- b. A player makes no attempt to draw.
- c. The first movement of the crosse is not up and away in any direction from the starting point.
- d. The ball fails to go higher than the heads of both players taking the draw.
 - 1) To resume the game after a player draws illegally, player positioning for the draw will apply. The opponent will be awarded a free position at the center line. The player on the team that fouled will move 4 m away toward her team's defending goal at a 45° angle to the center line. Players must stand for the free position.

RULE 19 / MINOR FOULS & PENALTIES

- 2) If both players draw illegally, or it cannot be determined why the draw was illegal, or the umpire determines the draw was unsuccessful because it was not set correctly, the umpire will call time out and reset the draw.
Exception: Upon agreement prior to the game, if one team is ahead by 12 or more goals, time out will not be taken to reset the draw. (Rule 10.D.1)
10. During the draw, players must not step on or over the center circle line or the restraining lines before the whistle sounds to start play. (Rule 12.B)
 - a. When called, the opponents will be awarded a free position for an illegal draw at the center line. (Rule 19.A.9.d.1)
Guidance: This rule applies if a player or her team gains a clear advantage because of the violation.
11. During the draw, goalkeepers must remain below/goal side of their team's defensive restraining line. At all other times during the game, the goalkeeper must remain above/behind her team's offensive restraining line.
 - a. If the goalkeeper is penalized for being above her defensive restraining line during the draw, she must move back on side, and the opponents will be awarded a free position for an illegal draw at the center line. (Rule 19.A.9.d.1)
Guidance: This rule applies when a goalkeeper or her team gains a clear advantage because of her illegal position.
 - b. If a goalkeeper is penalized for being goal side of her team's offensive restraining line, she must move back on side and 4m away from the nearest opponent, who will be awarded a free position just above the restraining line.
12. A player must not intentionally delay the game. (Rule 22.C)
13. A player must not take part in a game if any part of her uniform is illegal, including illegal jewelry or the absence of a mouth guard. Time out will be called and the player must leave the field to correct the violation before reentering the game through the

RULE 19 / MINOR FOULS & PENALTIES

team substitution area when play resumes. **Exception:** When the game is stopped because a player is not wearing a mouth guard and her mouth guard is on her person when the foul is called, she may put her mouth guard in her mouth and remain on the field.

- a. To resume play, the opponents will be awarded a free position at or near the spot of the ball.
 - b. If the violation is discovered immediately after a goal is scored and before the next draw, the goal will count. To resume play, a free position will be awarded at the center line. Player positioning for the draw will apply; players must stand. (Rule 13.B)
14. A player must not play with illegal equipment. An umpire may take time out at any time during the game to re-inspect the pocket of a crosse or other equipment. Any player on the field may request an umpire to check the pocket of an opponent's crosse. The player requesting the stick check must provide the umpire with the shirt number of the opponent whose crosse will be checked. (Rule 19.A.15)

Guidance: Umpires must be alert to sagging pockets and crosses that hold the ball after successive hard checks.

- a. If the equipment is legal, the game will be restarted by awarding the ball to the player who was in possession of it when time out was called. If neither team had possession of the ball, a throw will be awarded to the two opponents who are nearest the spot of the ball.
- b. If the equipment is illegal, it will be placed at the scorer's table for the remainder of the half. The opponent nearest the spot of the ball will be awarded a free position. The player may continue to play with equipment that is legal.
- c. If a goal is scored with an illegal crosse, and the illegal crosse is discovered before the game is restarted with a draw, the goal will not count. All players must stand, and the opposing goalkeeper will be awarded a free position within her goal circle.

RULE 19 / MINOR FOULS & PENALTIES

- d. If any player other than the shooter is found to have an illegal crosse after a goal is scored and before the game is restarted with a draw, the goal will count. The game will resume with a free position for the opponents at the center line. Player positioning for the draw will apply; players must stand.
Guidance: When a crosse check is requested immediately after a goal, umpires must quickly call time out and require players to stand until the pocket is checked.
15. A team must not request for a second time during a game, or any additional times, the inspection of an opponent's crosse when it meets specifications. A free position will be awarded at the spot of the ball or where play was to resume before the crosse was checked.
16. A player must not adjust the thongs of her crosse after an umpire requests to inspect her crosse.
Guidance: A player may adjust the thongs on her crosse at any time during the game before an umpire makes a request to inspect her crosse. When a player adjusts her thongs after an umpire asks to check her crosse, the crosse is ruled illegal and must be placed at the scorer's table for the remainder of the half.
17. A player must not substitute illegally. (Rule 11 and 22)
- a. The umpire will call time out and remove the illegal player from the field. The free position will be awarded to the opponent in possession of or nearest to the ball.
- b. If an illegal player is discovered on the attacking team after a goal is scored, but before the next draw, the goal will not count. The illegal player will be removed and the opposing goalkeeper will be awarded a free position inside her goal circle. Exception: If the illegal player is also offside, the minor offside foul will be penalized when play resumes. (Rule 18.B.7)
18. A goalkeeper must not score a goal for her team.
- a. The goal shall not count, and all players must stand. The opposing goalkeeper will be awarded the free position inside her goal circle.

RULE 19 / MINOR FOULS & PENALTIES

19. A player must not hold the crosse of an opponent for a short time during a check/tackle.

Guidance: A minor foul hold occurs most often during ground ball play. (See Rule 20.A.14; major foul holding/detaining)

20. Players must not false start/move their feet before the umpire's whistle. A player, who feints or simulates a false start that is designed to cause their opponent/s to move before the whistle, will be penalized and may be carded.

Guidance: A player must not be penalized for a false start if the false start is caused by an umpire, or if the umpire is not ready to start play.

21. A team must promptly return to the field for the center draw, following half time, team time outs, and goals.

- a. The free position will be awarded at the center line. Both teams will take their legal positions for a draw before the umpire awards the ball to the team that was ready to play.

B. Minor Foul Free Positions:

1. For all minor fouls that occur **outside the 15 m fan or below the level of the goal line extension**, award the free position where the foul occurred, at least 11 m from the center of the goal circle and 4 m inside the boundary. The player who fouled will move 4 m away from the opponent awarded the ball in the direction from which she approached her opponent before committing the foul. This applies to the goalkeeper if she commits a minor foul while she is completely (both feet) are outside the goal circle.
2. When the **defense commits a minor foul within the 15 m fan** (no advantage flag/scoring play), the attack player who was fouled will be awarded a free position at a spot on the 15 m fan that is nearest to and in line with the foul. The defender who fouled will move 4 m away from the attack player relative to her field position/relationship with that player at the time of the foul.

Guidance: Umpires are encouraged to hold whistle if a minor foul is committed by the defense when an attack player may have an opportunity to shoot.

RULE 19 / MINOR FOULS & PENALTIES

- a. When the goalkeeper commits a minor foul, and she is partially or completely inside the goal circle, she remains in the goal circle for the free position. No other defense player is required to move to within 4 m of the free position.
- b. Whenever the goalkeeper is completely (both feet) outside her goal circle and she commits a minor foul, she will be penalized as a field player and must move 4 m away from the player taking the free position. (Rule 17.A.6)
3. When the **attack commits a minor foul inside the 15 meter fan** (no advantage flag/scoring play), a free position will be taken by the defender who was fouled at a spot nearest to and in line with the foul. The free position may not be set within 11 m of the center of the goal line unless the goalkeeper was fouled while she was inside her goal circle. The attack player who fouled will move 4 m away relative to her field position and relationship with the defender at the time of the foul.
4. When the **attack commits a minor foul during a raised advantage flag**, a throw will be awarded to resume play. (Rule 21.C.4)
5. When fouls occur during the draw, play will resume with free position at the center line. (Rule 19.A.9, 19.A.10 & 19.A.11)
6. Any recurring delay of game and/or repeated or persistent minor fouls may be carded and penalized as major fouls.

***Guidance:** A number of players are attempting to win possession of a ground ball. The ball takes a bad bounce, hits the back of B1's leg, and goes directly to her teammate B2. **Legal:** play on. B1 did not make any attempt to 'deliberately' play the ball off of her leg.*

*A player in Red is awarded a minor foul free position, and the umpire notices that she is not wearing a mouth guard. The player in Red removes her mouth guard from her sock and puts it in her mouth. To resume play, the umpire awards the opponents in Blue the free position. **Legal:** the player in Red is not required to leave the field because she has her mouth guard on her body. However, to resume play, the opponents are awarded a free position.*

RULE 20: MAJOR FOUL RULES AND PENALTIES

A. Major Foul Rules

1. A player must not roughly or recklessly check/tackle an opponent's crosse. Players must not check an opponent's crosse from within a field crosse width of a player's head (a distance of approximately 18 cm or the width of a player's shoulders). The direction of a check must be away from a player's head/neck, and checks must be controlled, not intimidating or dangerous.

***Guidance:** A check that causes the ball to go toward an opponent's face or a check that forces an opponent's crosse into her body is illegal.*

An attack player must not turn into or force her crosse or body into an opponent's body or a legally held crosse, thereby, checking herself. Watch for an attack player illegally forcing through a legal defensive double team.

2. A player must not strike an opponent with her crosse or force an opponent's crosse into an opponent's head or body. A yellow card **must** be given for a check that makes contact with a player's head.

***Guidance:** Unbalanced body position, stationary feet, and slipped hands on the shaft of the crosse may result in large sweeping swings that are reckless and dangerous. To determine the legality of a check, umpires must consider the amount of force, and the extent and direction of the back swing and the follow-through. However, loud checks are not necessarily illegal checks.*

3. A player must not hold her crosse within a field crosse width of an opponent's head or neck. A defender must not poke or wave a crosse near or toward an opponent's face or body.
4. A player must not reach around or across her opponent's body to check the opponent's crosse when her feet are behind or level with the opponent; with or without contact.

***Guidance:** The defender's feet must be ahead of an opponent before she may attempt to reach around/across her body. This rule does not prohibit a defender from legally checking an attack player's crosse from behind.*

RULE 20 / MAJOR FOULS & PENALTIES

5. A player in possession of the ball must not protect her crosse by holding her crosse near her own or a teammate's face or body, with or without cradling; thereby, making a legal check impossible.

***Guidance:** The defense must be allowed to legally check an opponent's crosse. This foul should be called when the attack player pulls her crosse in toward her head/body to prevent defender who is in good defensive position from making a legal play on the ball. This foul occurs most often when an attack ball carrier becomes trapped in or tries to go through a legal double team.*

6. A player must not block, charge, barge, shoulder, push with the hand, back into an opponent, or force her way through a legal double team. A player is entitled to a legal field position that is not already occupied by an opponent, and in taking that field position, she must allow the opponent the time and/or space to stop and/or change direction to avoid contact.

***Guidance:** A player's legal defensive position is as wide as her shoulders. It includes the space directly in front her extending as far as the length of her outstretched arms and her 'nominally' upright torso. A defender holding this position must be in this position before the attack player reaches her, and she must not extend her knees or hips sideways to impede, with contact, an attack player who is changing her path to goal.*

It is charging if an attack player uses her body or crosse to interfere with and make body contact with a defender who is moving with her opponent to maintain legal body position ('body checking'). This includes interference with a defender's legally held crosse.

Body-to-body contact may be called a charge, a block, or incidental contact (a no call). Crosse-to-crosse contact is either legal or illegal.

7. A player must not at any time propel the ball with her crosse in a dangerous or uncontrolled manner. A yellow card must be given for dangerous propelling.

RULE 20 / MAJOR FOUL RULES & PENALTIES

- a. The penalty for dangerous propelling is awarded to the endangered player at or near the spot from where the dangerous ball was thrown; at least 11 m from the center of the goal line.

Guidance: A pass that is thrown or a shot that is taken without regard to the positioning of any field player is potentially dangerous.

A defender D1 is legally marking an attack A1 in front of goal. The attack player with the ball, A2, shoots from just outside the marking area as A1 ducks out of the way. Illegal: A2 must be carded for dangerous propelling, and D1 is awarded a free position on the 11 m hash mark nearest to where A2 took the shot.

8. A player must not, at any time, follow-through with her crosse in a dangerous or uncontrolled manner. A yellow card must be given for a dangerous follow-through.

Guidance: A dangerous follow-through should be called if the defender has already established her legal defensive position before the shot. The shooter should not be penalized if a defender moves into the path of the stick/follow-through after the ball has been released.

Because the lead umpire must follow the ball on a shot, a trail umpire may be the one who best sees the illegal contact on a follow through.

9. A player must not shoot dangerously or without control. A dangerous shot is usually directed at the goalkeeper. A dangerous shot is judged on any combination of the shooter's **distance** from the goal, the **force** of the shot, and the **placement** of the shot. A shot may be judged dangerous and/or uncontrolled even if it misses the goal.

Guidance: When judging a dangerous shot, consider: Did the shooter hurl or bat the ball at goal without regard for her opponents or teammates? Was the shooter off balance? Taking into account a player's peripheral vision, did the player shoot blindly? Was the shot a hard, rising shot aimed directly at the goalkeepers body/head?

RULE 20 / MAJOR FOUL RULES & PENALTIES

- a. The goalkeeper will take the free position from inside the goal circle for all dangerous shots. The offending player will move directly behind and 4 m away from the goal circle.
 - b. If a goalkeeper has time to react and/or moves into a shot, it is not dangerous. Shots that become dangerous after a legal defensive check or block should not be penalized. A shot that becomes dangerous when a goalkeeper misplays the ball is not a dangerous shot.
10. A player must not deliberately push, flick, or bat the ball into an opponent's feet or body to cause the ball to go out of bounds. (Rule 14)
11. A defense player must not block or guard the goal outside the goal circle with any part of her body for the purpose of **'obstructing the free space to goal'**. Obstructing the free space to goal denies the attacking team the opportunity to shoot safely. This rule is in effect only when the attacking team is in possession of the ball within the 15 m fan. (Rule 23: Diagram 9)
- a. Obstruction of the free space to goal occurs when a defender is illegally in the free space at her own initiation.
 - b. A defender is not obstructing the free space if she is drawn into and through the free space to goal by an attack player whom she is legally marking **'within a stick's length'**, approximately 1.5 meters. (Rule 23: Definitions)
Guidance: When a defender is being drawn through the free space by an opponent she is marking and she continues to move through the free space without hesitating or stopping, she must not be penalized for obstructing the free space to goal.
 - c. Blocking the free space to goal requires an immediate whistle in order to prevent injury. The free position will be set relative to the spot of the ball. (Rule 20.B.5)
Guidance: This call should be made only if the ball carrier is looking to shoot, and has the opportunity to shoot.

RULE 20 / MAJOR FOUL RULES & PENALTIES

If she has her back toward the goal and/or she is being double or triple teamed, she does not have an opportunity to shoot.

When approaching the ball carrier, a defender's body, not her crosse, must be outside the free space until she is within a stick's length of the ball carrier.

Defenders who are within a stick's length and double teaming a player without the ball are exempt from obstructing the free space to goal, but they must abide by the three-second rule.

A player standing below the goal line extended is not obstructing the free space to goal.

12. A defender must not remain in the marking area in front of the goal circle for more than three seconds unless she is marking an opponent within a stick's length. Only one defender may mark the same non-ball player in the marking area.

A defender who is marking an unmarked opponent standing **'directly behind the goal circle'** is exempt from the three seconds rule, but she is not exempt from obstructing the free space to goal. She may not remain in the 11 m area for more than three seconds if one of her teammates moves behind goal to directly mark the attack player. (Rule 23, Diagram 8)

A defender who is inside the marking area because she is legally marking an unmarked opponent who is directly behind goal cannot be penalized for the three seconds rule when drawn into a double team in front of goal by other attack non ball players.

The three seconds rule takes effect when the team in possession of the ball crosses the ball over the restraining line into their attacking end of the field. When the defense is called for a three-second violation and:

- a. The attack player in possession of the ball is above or below the goal line extended, the free position will be set relative to the position of the ball to restart play.

RULE 20 / MAJOR FOUL RULES & PENALTIES

- b. The advantage flag was raised for the violation, and the scoring play ends without a further foul or shot on goal. The free position will be set relative to the spot of the ball when the flag was raised. (Rule 21.D.3)
13. A player must not initiate illegal contact by detaining, holding, tagging, or pushing against an opponent's body, clothing, or crosse with her arm, leg or body. A player must not use the shaft of the crosse to hit, push, or displace an opponent.
14. When a player is in possession of the ball, an opponent must not hold the player's crosse after a check, which impedes the player's movement or balance. (See Rule 19.A.19 for the minor foul hold.)
15. A player must not use the webbed area of her crosse to hook the bottom end of an opponent's crosse.
16. A player must not trip an opponent, deliberately or otherwise.
17. A player must not set a moving or stationary pick that is out of an opponent's **'visual field'**, does not allow enough time or space for the opponent to stop or change direction, and contact occurs.
Guidance: Illegal picks set during high speed midfield transition may be dangerous and carded.
18. A player must not **'swipe'** at her opponent with her crosse. A swipe is a reckless and dangerous swing of the crosse that has potential for serious injury. A swipe will be called regardless of whether or not contact is made with an opponent's crosse or body. In addition to awarding the appropriate penalty, a yellow card **must** be given.
Guidance: Swipes occurring in the midfield must be called immediately. Swipes that occur during a raised advantage flag / scoring play must be carded and penalized when the scoring play ends.
19. The goalkeeper, while fully outside the goal circle, must not blatantly or purposely play the ball with any part of her body.
20. An unprotected field player/deputy may not illegally remain in the goal circle. (Rules 17.A & 17.C.1.b)

RULE 20 / MAJOR FOUL RULES & PENALTIES

21. A player or any other team/bench personnel must not act in an unsporting manner or display any other inappropriate behavior. Coaching during an injury time out is not permitted.
 22. A player must not use her crosse and/or body in a forceful, dangerous or intimidating manner and/or show disregard for her own or an opponent's safety. This ruling applies to all players regardless of whether or not they have possession of the ball. (Rule 22)
- B. Major Foul Free Positions
1. For any major fouls that occur anywhere on the field **outside the 11 meter area, including below the level of the goal line extended** (no advantage flag/scoring play), the free position is awarded at the spot of the foul, but no closer than 11 m to the center of the goal line or within 4 m of the boundary. The offender will stand 4 m directly behind the player taking the free position. If the goalkeeper is outside her goal circle and has not fouled, she must stand for the free position and may not return to the goal circle.
 - a. Whenever the goalkeeper commits a major foul, regardless of whether she is in or outside the goal circle, she must move 4 m behind the player awarded the ball for the free position; the goal circle will remain empty. When play resumes, a deputy may only enter the goal circle to stop a rolling or a low bouncing ball.
Guidance: A bounce shot is not a low bouncing ball.
 2. When a major foul by the defense occurs **within 11 meters outside the marking area (in the "pie" shaped area)**, the free position is set on the nearest hash mark in line with the foul. Only the **'penalty lane'** will be cleared. All players must move their bodies and crosses sideways from the penalty lane relative to their positions when play stopped. (Rule 23: Diagram 10)
 - a. If the goalkeeper is outside the goal circle and has not fouled, she must return to the goal circle for the free position.

RULE 20 / MAJOR FOUL RULES & PENALTIES

3. When a major foul by the defense occurs **inside the marking area**, the free position is set on the hash mark inside the marking area that is nearest to and in line with the foul. All players must clear their bodies and crosses from inside the marking area. The penalty lane must also be cleared when the free position is awarded on either of the first hash marks inside the marking area.
 - a. When instructed by the umpire, all players must clear the marking area by taking the shortest route out. Designated defense players are entitled to a position on the hash marks closest to the attack player who is awarded the free position. Designated defense players are those players who are within 4 m of the attack player who was fouled, or when the whistle sounds to stop play, are within 4 m of the attack player who is awarded the free position.
 - b. If the goalkeeper is outside her goal circle and has not fouled, she must return to the goal circle for the free position.
4. If a foul by the defense prevents an almost certain goal, the umpire may move any player/s, including the goalkeeper, who are positioned between the free position and the goal. The goal circle will remain empty. (Rules 20.A.11, 20.A.12; 20.A.19, 20.A.20 & 20.A.22)
5. If any defender is in the free space to goal when a free position is set, she must not be penalized for blocking the free space to goal unless she does not immediately move out when the whistle sounds to restart play. (Rule 20.A.10)

Guidance: While a defender must not be allowed to obstruct the free space to goal, an attack player must never shoot/ propel the ball at an unprotected player.
6. When a major foul by the attack occurs **inside the 11 m area**, (no advantage flag/scoring play) the free position will be taken by the defender who was fouled at a spot in line with the foul that is 11 m from the center of the goal line. The attack player who fouled will move 4 m behind.

RULE 20 / MAJOR FOUL RULES & PENALTIES

- a. If the goalkeeper is fully outside the goal circle when she is fouled by an attack player, the goalkeeper will take the free position 11 m from the center of the goal circle at a spot in line with the foul.
 - b. If an attack player fouls the goalkeeper while she is inside or partially inside the goal circle, the goalkeeper will take the free position inside the goal circle. The offender will move behind the goal circle and 4 m away.
7. Whenever a warning card is given for a personal foul, the game will resume according to Rules 20.B & 22.B.

Guidance: When a warning card is given for a personal foul following a scoring play, play will resume according to Rule 21.D.5.

RULE 21: ADVANTAGE FLAG

- A. The Advantage Flag is a held whistle for a major foul committed by the defense when the attacking team is on a **‘scoring play’** within 15 meters of goal. A scoring play is a continuous effort by the attacking team to move the ball toward goal to complete a shot.
- I. The advantage flag area includes the 15 m fan and the playing area behind the goal that runs 9 m deep and 15 m to each side of the center of the goal line.
- B. The umpire will raise a yellow flag when the attack is on a scoring play within the advantage flag area and the defense commits a major foul against an attack player with the ball, or an attack teammate without the ball. The flag will remain raised as long as the attack retains possession of the ball and moves toward goal to complete a shot.

Guidance: Umpires will keep the yellow flag in the waist band or pocket of their uniform. When a scoring play is in progress and the defense commits a major foul, the umpire will hold the advantage flag vertically above her head so that the flag is clearly visible and call “Flag”. The umpire must note the shirt numbers of both the attack and defense players involved. (Rule 23: Diagram 7)

RULE 21 / ADVANTAGE FLAG

C. The scoring play is complete and ends when:

1. A shot is taken.
2. The attacking team passes or carries the ball behind the level of the goal line and fails to continue their initial momentum to score a goal.

Guidance: An attacking team must not be permitted to take or pass the ball behind the level of the goal line to set up a new scoring play.

3. The attacking team stops its continuous effort to complete a shot on goal, or the player with the ball is forced by the defense to lose her forward momentum.

Guidance: Umpires will end the scoring play if the attack is forced by good defensive play to lose its forward momentum to goal, or if the attack simply stops moving to goal.

4. The attacking team fouls. If the attacking team commits any major or minor foul during a scoring play, the fouls will be treated as equivalent and offsetting foul. To resume play, a throw will be taken beyond 15 m and level with the goal line extended. (Rule 15.B.9)

Guidance: When possible, it is recommended that the center/ "C" umpire administer throws.

5. The attacking team loses possession of the ball. A bounce pass or shot are not considered loss of possession.

Guidance: The attack may lose possession of the ball by dropping the ball, making an errant pass that is intercepted or goes out of bounds, or from a legal check.

6. The defense commits another major or minor foul that requires the game to be stopped.

Guidance: During a scoring play/raised advantage flag, it is not necessary to automatically stop play when there are additional/subsequent defensive fouls. However, the scoring play may be stopped at any time to prevent injury.

Fouls that are judged intentional, professional, or breakdown fouls must be carded.

RULE 21 / ADVANTAGE FLAG

- a. The umpire must stop the scoring play immediately for an obstruction of the free space violation or for an illegal deputy inside the goal circle.
- D. Following the Advantage Flag:
1. If a shot on goal is successful, the goal counts.
 2. If the attacking team chooses to shoot, the 'advantage' indicated by the raise flag is complete, the umpire lowers the flag and play continues.
 3. If the scoring play ends without a further foul or a shot on goal, or if a shot on goal is directly and immediately affected by a foul and no advantage is gained, a free position will be awarded to the player who was fouled. The opponent who fouled will move 4 m directly behind. If the foul occurred:
 - a. **Within 11 meters outside the marking area** (in the 'pie' shaped area), the free position is set on the nearest 11 m hash mark. Only the penalty lane will be cleared of players' bodies and crosses. (Rule 20.B.2)
 - b. **Inside the marking area**, the free position is set on the nearest hash mark inside the marking area. The marking area and, when necessary, the penalty lane must be cleared. (Rule 20.B.3)
 - c. **Below the level of the goal line or if the goalkeeper saves the shot**, the free position is set on the nearest 11 m mark on the goal line extended. Players will clear a penalty lane above/in front of the goal line.
 4. If the defense commits any subsequent/additional major or minor foul/s anywhere inside or outside the marking area that ends the scoring play, the free position is set on the 11 m hash mark inside the marking area that is nearest to the most recent foul. The defender who fouled will move 4 m behind. The marking area and, when necessary, the penalty lane will be cleared. Exception: If the additional foul is called for a deputy who is illegally inside the goal circle, the free position will be awarded at the center hash mark in the marking area. (Rule 17.C.b)

RULE 21 / ADVANTAGE FLAG

5. If the defense commits a major foul that must be carded when the scoring play ends, the attack will be awarded a free position according to the criteria in Rules 21.D.3 and 21.D.4. Since the defense will be playing with one less player below the restraining lines, no other player on the defending team will be required to move 4m behind for the free position.
 - a. If the attack scores a goal, the free position will be awarded at the center line. The center on the team that fouled will move 4 m away toward her defending goal at a 45° angle to the center line.
 - b. If the goalkeeper receives a warning card following a goal, the goalkeeper or her substitute will remain in the goal circle to resume play. To resume play, the free position will be set at the center line. (Rule 22.B.2 & 22.B.3)
6. If the attacking team commits any major or minor foul during a scoring play, to resume play see Rule 21.C.4.
7. The goalkeeper may return to the goal circle if:
 - a. She has moved outside the goal circle and makes an interception, wins possession of an out of bounds ball or makes any other legal play to end the scoring play.

***Guidance:** While the attack is on a scoring play, the advantage flag is raised for a major foul committed by the defense just inside the 15 m fan. As the attack continues toward goal, she passes the ball toward a teammate near the goal circle. The goalkeeper moves out of her goal circle and intercepts the pass. **Legal:** the fouled attack player is awarded a free position set at the spot of the foul just inside the 15 m fan, the defender who fouled must move 4m behind, and players within 4 m of the ball carrier must move 4m away. Since the goalkeeper ended the scoring play, she may return to the goal circle for the free position.*
 - b. The goalkeeper has moved outside the goal circle and is fouled by an attack player, which ends the scoring play.

***Guidance:** A Throw will be awarded to the attack player who fouled and the nearest defender, not the goalkeeper.*

RULE 21 / ADVANTAGE FLAG

- c. The goalkeeper is outside the goal circle, has not fouled, and the free position is set within the 11 m area.

RULE 22: WARNING CARDS AND MISCONDUCT

A. Personal Misconduct Fouls. A player must not:

1. Conduct herself in a rough, dangerous, or unsporting manner.
2. Persistently or flagrantly violate the rules.
3. Deliberately endanger the safety of an opponent.
4. Use abusive language or excessively dissent the umpires' decisions.
5. Use language or exhibit behavior that is intended to embarrass, ridicule or demean others, i.e. baiting or taunting.
6. Exhibit any type of behavior which in the umpire's opinion amounts to misconduct.

***Guidance:** A card must be given for a check to the head, a swipe, a dangerous follow-through, and dangerous propelling. Discretionary cards may be given for other persistently occurring major fouls due to either lack of skill, recklessness, or an attempt to gain an unfair advantage.*

B. Penalties for Personal Misconduct Cards

1. The penalty for personal misconduct suspensions will be the same as for all major fouls. In addition to awarding a free position, the umpire will take time out to issue a yellow card, a yellow and red card together, or a straight red card. Whenever a warning card is shown, it is considered a warning to all players.
 - a. When administering a free position after a card has been given and a team is playing with one less person, no player on the penalized team must move 4 m behind for the free position. A carded player will serve her timed suspension in her team's bench area.

RULE 22 / WARNING CARDS & MISCONDUCT

2. A player receiving a yellow card must leave the field for a two minute timed penalty suspension; a substitute may not take her place. Her team must play with one less player below/goal side of the restraining lines for the duration of the two minute penalty.
 - a. If a goalkeeper receives a yellow card, and her team has a 'second dressed' goalkeeper, the second goalkeeper will replace the goalkeeper. If her team does not have a 'second dressed' goalkeeper, the goalkeeper may remain in the game.
 - b. To resume play the goalkeeper will stand 4 m behind the attack player awarded the free position. The goal circle will remain empty. The teammate below/goal side of the restraining line and nearest to her team's substitution area must leave the field to begin the two minute suspension penalty.
 - 1) Exception: If the goalkeeper receives a warning card following a successful shot on goal, she or her substitute will remain in the goal circle. Play will resume with a free position at the center line. (Rule 21.D.5.b)
 - c. Once play resumes, any eligible player may substitute as long as her team plays short for the duration of the two minute penalty.
3. A player receiving a yellow/red card or a straight red card will be suspended from further participation in the game; a substitute may not take her place. Her team must play short with one less player below/goal side of the restraining line for the duration of five minutes for a yellow/red card and ten minutes for a straight red card.
 - a. When a goalkeeper receives a yellow/red or a straight red card, and her team has a 'second dressed' goalkeeper, she will replace the suspended goalkeeper. If the suspended goalkeeper is her team's 'only dressed' goalkeeper, a two minute time out will be taken to enable a teammate to put

RULE 22 / WARNING CARDS & MISCONDUCT

on protective equipment. If this player is on the field a substitute will take her place. Play will resume according to Rule 22.B.2.

4. If a player or substitute enters the game before a timed penalty suspension expires, the player or her team must re-serve the entire penalty and play short for another two, five, or ten minutes.
5. Whenever a player is suspended with less than two minutes remaining in the half for a yellow card, five minutes for a yellow/red card, or ten minutes for a straight red card, the timed penalty suspension will carry over into the second half or overtime, when played.

***Guidance:** An advantage flag has been raised for a major foul committed by the defense while the attack was on a scoring play. As the attack player shoots, the goalkeeper checks the attack shooter on the head; the shot goes in the goal. **Illegal:** the goal counts, and the umpire must give the goalkeeper a yellow card. To resume play, the attack is awarded a free position at the center line. The goalkeeper or a substitute will remain in the goal circle, and a field player on the defending team must leave the field to begin the goalkeeper's suspension. (Rules 21.D.5.b & 22.B.2)*

6. Without any previous warning, an umpire may suspend a player, coach or other team/bench personnel from further participation in the game if they are guilty of flagrant or repeated violations of the rules, continued dissent, misconduct, or abusive language.
 - a. The suspended person will be requested to leave the field and the entire playing area. The game will be restarted within 30 seconds with a free position for the opponent nearest the ball when play was stopped or at the spot where play was to resume before the card was given.
 - b. If the offender refuses to leave the field and/or playing area when requested by the umpire, her team must forfeit the game. If the forfeiting team is behind in score, the score will stand. If the forfeiting team is ahead, the score will be 1–0 in favor of the opponents.

RULE 22 / WARNING CARDS & MISCONDUCT

- C. Delay of Game and other Persistent Minor Fouls
1. Delay of game fouls include:
 - a. Failure to 'stand' when the whistle is blown to stop play; **'creeping'**,
 - b. Failure to move 4 m away for a free position,
 - c. Failure to follow an umpire's directions,
 - d. Any other type of behavior which, in the umpire's opinion, amounts to delay.
 2. Persistent minor fouls include:
 - a. Repeated false start violations (Rule 19.A.20)
 - b. Repeated restraining line violations (Rule 18)
 - c. Teams that repeatedly waste time returning to center draw following a goal (Rule 19.A.12)
 - d. Any other minor fouls that in an umpire's opinion occur repeatedly due to lack of skill or to gain an unfair advantage.
- D. Penalties for Delay of Game and other Persistent Minor Fouls
1. The first time an umpire awards a card for delay of game or persistent minor fouls, the umpire will show the team's captain a green card, and award the appropriate minor foul free position, if applicable, at the spot of the ball.
 2. For the second delay of game or persistent minor foul penalty, the umpire will show the offending player a green and yellow card together and award the appropriate major foul penalty. The offending player may remain in the game.
 3. For the third or any subsequent delay of game or persistent minor foul penalties, the umpire will show the offending player a green and red card together and award the appropriate major foul penalty. The player must leave the field for a five minute timed penalty suspension. To resume play, no other player on the team that fouled must move 4 m behind for the free position.
 - a. During the five minute penalty suspension, the player's team must play short with one less player below/goal side of the restraining lines. When the time expires, the player or a substitute may enter the game.

RULE 22 / WARNING CARDS & MISCONDUCT

- b. If the suspended player or her substitute enters the game before the penalty expires, she is an illegal substitute. The player must leave the field to re-serve the penalty, and her team must play short for an additional five minutes.
 - c. Whenever a player is suspended with less than five minutes remaining in the half, the suspension will carry over to the second half or overtime when played.
6. Delay of game and other persistent minor fouls need not be identical.
- E. The warning card procedures for personal misconduct fouls and those for delay of game and other persistent minor fouls operate independent of one another. Therefore, it is possible for a player to receive a yellow card and then receive a yellow/green card.
- F. At any time during the game, at an umpire's discretion and without previous warning, an umpire may award cards for personal misconduct fouls or for any delay of game or other persistent minor fouls that are committed in a dangerous or unsporting manner.

Guidance: Delay of game and other minor fouls are generally procedural or involve misplays on the ball that do not relate to the safety of the participants. However, when these fouls are repeated, they must be carded. Personal misconduct major fouls, which include deliberate, 'professional' and 'breakdown' fouls, must be carded because they intimidate, jeopardize the safety of the participants, and reflect unsporting tactics.

The recommended options for the green, yellow, and red cards are:

- a. *A green triangle with sides 6.5 cm*
A yellow square with sides 6.5 cm
A red rectangle with sides 6.5 cm

OR

- b. *A green, yellow and red rectangle with sides 9 cm X 6.5 cm*

RULE 23 / DEFINITIONS

Body Checking is a technique whereby a defender moves with an opponent without body contact occurring. The defender mirrors each movement of the opponent's body and crosse with her own body thereby causing her opponent to slow down, change direction, or pass the ball.

Charging occurs when a player with the ball, pushes into, shoulders, or backs into and makes bodily contact with her opponent who has already established her legal defensive position, though not necessarily stationary. (Rule 20.A.6)

Clear is any action taken by a player who is legally inside the goal circle to pass or carry the ball out of the goal circle.

Clear Space indicates the space between players which is free of crosses or any part of another player's body.

Creeping is illegal movement by a field player after a whistle is blown to stop play when players are required to stand.

Crosse Checking is an extension of body checking whereby the defender attempts to dislodge the ball from an opponent's crosse by using controlled crosse-to-crosse contact.

A Dead Ball occurs when an umpire blows the whistle to stop play; the ball is referred to as being "dead".

A Deputy is an unprotected field player on the defensive goalkeeper's team who may enter or remain in the goal circle only when her team is in possession of the ball and the goalkeeper is out of the goal circle. (Rule 17.A.3)

Directly Behind the Goal is the area between two imaginary lines extending perpendicular and back from the goal line extended and tangent to the goal circle. (Rule 20.A.12)

RULE 23 / DEFINITIONS

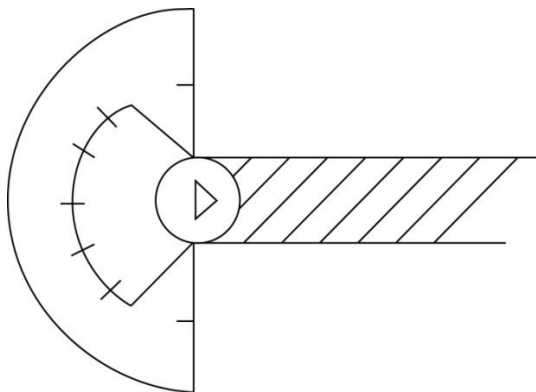

Diagram 8
Directly Behind the Goal Circle
Rule 20.A.12

False Start: Players may not move their feet, step or make any movement feinting/simulating the beginning of play that is designed to cause an opponent to move before the whistle.

Free Space to Goal is an imaginary path to goal as defined by two lines extending from the ball, which must be within 15 m of goal, to the outside edges of the goal circle. No defender will be penalized if positioned below the extension of the goal line, as shown. (Rule 20.A.11)

RULE 23 / DEFINITIONS

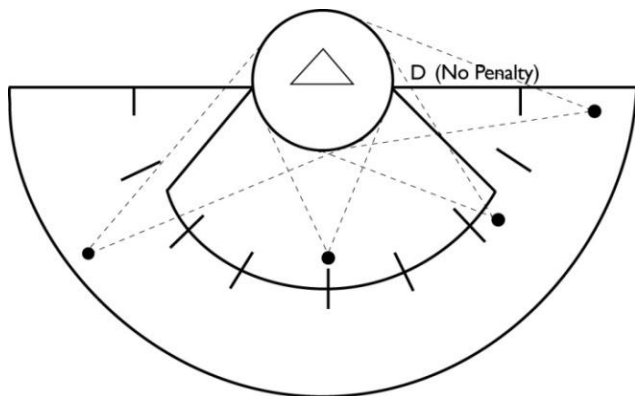

Diagram 9
Free Space to Goal
Rule 20.A.11

Grounded refers to any part of the goalkeeper's or a deputy's body/feet that are completely outside the goal circle line, while attempting to play the ball from inside the goal circle. (Rule 17.A.3.d)

Held Whistle: See Rule 16.C.

In Possession of the Ball means that a player has the ball in her crosse, and she can perform any of the normal function of control such as cradling, carrying, passing or shooting the ball. (Rule 14.B.1)

RULE 23 / DEFINITIONS

Penalty Lane is a path to goal defined by two imaginary lines that extend the width of the goal circle to 4 m on either side of the ball carrier. All other players must clear their bodies and crosses from this space when some free positions for major fouls are awarded within 11 m in front of goal.

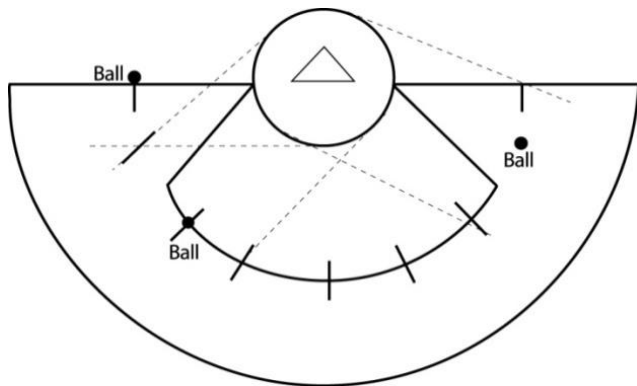

Diagram 10
Penalty lane
Rule 20.B.2

Pick is an offensive technique by which a player without the ball uses her positioning to force an opponent to take another route. To be legal, moving or stationary picks must be set within the 'visual field' of the opponent. The opponent must be given enough time and space to stop and/or change direction. (Rule 20.A.14)

Played refers to an action whereby the ball leaves the player's crosse and is touched by another player, or her crosse is checked crosse to crosse by an opposing player.

RULE 23 / DEFINITIONS

A Scoring Play is a continuous effort by the attacking team to move the ball toward the goal and to complete a shot on goal. A scoring play ends/is complete when:

1. A shot is taken.
2. The attacking team passes or carries the ball below the level of the goal line and stops the continuous attempt to score a goal.
3. The attacking team stops their continuous attempt to score a goal, or the player with the ball is forced by good defense to lose her forward momentum.
4. The attacking team fouls.
5. The defense commits another major or minor foul that requires the game to be stopped.
6. The attacking team loses possession of the ball.

Shot occurs when a player throw/propels the ball in the direction of the goal with the intent to score a goal.

Spot Nearest the Foul is on a line that passes from the center of the goal line, through the point where the foul occurred, to the 15 m fan.

Swipe occurs when a player swings her crosse at an opponent's crosse or body with deliberate viciousness or recklessness, whether or not the opponent's crosse or body is struck. (Rule 20.A.18)

Team/Bench Personnel includes the coach, assistant coaches, manager, medical staff and players. (Rule 1.J & Rule 22.B.6)

Team Substitution Area is the space defined by two markers placed 4 m apart and even with the Scorer's/Timer's table extended. Players waiting to substitute must stand behind the markers. (Rule 1.J)

Toeing the Center Line refers to the placement of the foot during the draw, up to, but not on, the center line. (Rule 12)

RULE 23 / DEFINITIONS

Visual Field is a player's peripheral vision. A player is responsible for using her peripheral vision to see her opponent/s. A player's peripheral vision is 180 degrees using a player's nose as the point of reference, not her shoulders. (Rule 20.A.17)

Within a Stick's Length is INSIDE a crosse length and arm's length extended (approximately 1.5m). It is the maximum distance a player may be from her opponent and be considered legally or actively marking this opponent. (Rules 20.A.11 & 20.A.12)

RULE 24: TOURNAMENT RULES

- A. For FIL events, a roster of eighteen (18) players constitutes a full team. Six (6) support staff are allowed in the Team/ Bench Area during games. (Rule 5.A)
- B. The color of the ball will be solid yellow.
- C. The scorekeeper will record the time of goals and any other necessary game statistics.
- D. If one team is leading by twelve (12) or more goals, the clock will continue to run after a goal is scored. (Rule 12)
- E. In Tournament Play, when there is a tie on points, it is recommended that the Goal Differential Formula will be applied:

Goals For – Goals Against

Total Goals

In the formula, the scores of all the games in the Round Robin of the tied teams are used. The maximum difference in scores allowed per team will be 12, which is achieved by reducing "Goals for". Actual scores are used except those matches in which the goal difference exceeds 12. In these cases, the goal difference is reduced to 12. For example, a score of 15 – 1 will be reduced to 13 – 1 before using the goal formula.

RULE 24 / TOURNAMENT RULES

- F. Overtime Procedures – Playing off a tie game when required.
1. When the score is tied at the end of regulation playing time, both teams will have 5 minutes rest and toss the coin for choice of ends. The lower seeded team or the team dressed in the dark shirts will call the coin toss for choice of end to defend.
 2. A full 6 minutes of stop-clock overtime will be played in sets of two 3 minute periods. At the end of the first 3 minute period, the teams will change ends with no delay for coaching, and the game will be restarted with a center draw. The team that is leading at the end of the full 6 minutes wins the game.
 3. When a team has not used its two team time outs during regulation, they may request a time out/s in overtime play.
 4. If the teams are still tied after the full 6 minutes of overtime, they will have 3 minutes of rest and change ends.
 5. The winner will be decided in a “sudden victory” stop clock overtime of not more than 6 minutes. If a winning goal is not scored in the first 3 minute period, teams will change ends with no delay for coaching, and the game will be restarted with a center draw. The team scoring the first goal wins.
 6. Play will continue with “sudden victory” stop-clock overtime periods of 6 minutes in length. Teams will continue to change ends after each 3 minutes of play. Teams will have 3 minutes of rest between every 6-minute period until a winning goal is scored.
- G. Penalty demerit system for FIL World Events.
1. For FIL Tournaments, a penalty point system will be in place for players receiving warning cards for personal fouls and to deter unsportsmanlike or dangerous conduct by players:
 - a. Yellow card suspension = 2 penalty points,
Yellow/red card suspension = 4 penalty points,
Red card suspension = 6 penalty points.
 2. When a player has accrued 8 penalty points, she will be suspended from the next match of the championship.

RULE 24 / TOURNAMENT RULES

3. Penalty points are cumulative. Once a player sits out one match, she will sit out a second match if she accrues an additional six points.
 4. It is the responsibility of the Technical Delegate or Competitions Chair to advise the Team Manager when a player has accrued six points.
- H. Uniform advertising: A maximum of 3 advertisement emblems/logos may be worn on the player's field uniform or body. Advertisement emblems/logos must not exceed 40 square centimeters.
- I. Uniform Shirts:
 - a. 1st Strip or Uniform (home team, higher seed, or light colored shirt.
 - b. 2nd Strip or Uniform (away team, lower seed or dark colored shirt.
 - c. Teams must have two alternate blood shirts in each color.
 - I. For FIL Tournaments, numbers 1-40 only are permitted on team shirts. Numbers at least 15 cm tall must be centered on the front of the shirt, and numbers at least 20 cm tall must be centered on the back of the shirt. Playing numbers must be written in plain block font, and the color of the numbers must clearly contrast the color of the shirts. If a team wears a patterned shirt, the numbers must be superimposed on a solid, clearly contrasting color block background. (Rule 6)
 - J. Technical Delegates will set tournament and bench rules in accordance with FIL Rules Book Rule I.J and FIL World Event Bylaws.

RULE 25: MANUFACTURER'S SPECIFICATIONS

A. All Field Crosses

The primary intent of the field crosse specifications is to ensure that the ball moves freely within all parts of the head and pocket so that the ball may be dislodged from a crosse without an excessively forceful check.

A crosse may be deemed illegal, even though it meets all technical specifications, if, in the opinion of the FIL Women's Rules Committee, its design is an obvious attempt to circumvent the intent of the rules.

A crosse that has been altered in such a way as to give an unfair advantage to a player is illegal.

1. The head of the field crosse shall be constructed of wood, plastic, fiberglass, nylon, leather, rubber, gut, and/or any other synthetic material.
2. The handle of the crosse shall be constructed of wood, metal alloy, or other composite material, and it must be 'nominally' straight. An exception is that a handle may deviate up to, but not more than, 10 degrees from straight at the end of the shaft that is within 6.5 cm from the ball stop when the handle is attached to the head.

*Guidance: A *bent* handle may only be used with the heads that are specifically designed to accommodate them; *Bent* handles are head and manufacture's specific. Heads designed for use with a *bent* handle will not be legal when mounted/attached to a straight handle. Heads designed for use with a straight handle will not be legal when attached to a bent handle.*

- a. Recessed metal screws with round heads shall be used to attach the head of a plastic/molded head crosse to the handle. The butt ends of all handles must have an end cap, be taped, or if wood, be sanded smooth. The crosse shall not have sharp or protruding parts or edges and shall not be dangerous to players in any way.

RULE 25 / MANUFACTURER'S SPECIFICATIONS

3. The overall length of the crosse shall be 0.9 m /90 cm minimum to 1.1 m /110 cm maximum. End caps are included when measuring the overall length of a crosse.
Guidance: Junior players who are under the age of 15 may use a crosse shorter than 90 cm/0.9 m to allow the crosse to fit comfortably along the full length of the player's arm.
4. To determine compliance with the line measurement specifications in Rule 25, all measurements shall be made to the nearest 0.01 cm. The allowed deviation from the standard is 0.09 cm.
Guidance: If the maximum specified length for a particular measurement is 5.1 cm, then a measurement of 5.19 cm passes and 5.20 cm does not. If the minimum specified length for a particular measurement is 5.1 cm, then a measurement of 5.01cm passes and 5.00cm does not.
5. The unstrung head and the handle of a field crosse shall lie within a 5.1cm horizontal plane. (Diagram 11)
Guidance: To determine the 5.1 cm horizontal plane of the head, place the crosse on a table with the open pocket facing up so that the long axis of the handle is horizontal/parallel to the floor. Depending on the shape of the head, it may be necessary to support the handle so it is horizontal. With the handle horizontal and the lowest part of the head in contact with the table, no part of the head, as defined from the ball stop to the outside edge of the Scoop, shall be more than 5.1 cm above the table.
 - a. At the bridge or the ball stop, the top edge of the bridge or ball stop must be at least 1.3 cm above the center line of the handle.
 - b. The top edge of the sidewall must not be more than 0.6 cm below the center line of the handle.
 - c. The top edge of the sidewall must not drop below the center line of the handle prior to 5.7 cm as measured from the center of the bridge or ball stop.
6. The overall length of the head, as measured from the center of the Bridge or Ball stop (where the top, back edge of the stop pad meets the plastic) to the top outside edge of the scoop, shall be

RULE 25 / MANUFACTURER'S SPECIFICATIONS

25.4 cm minimum to 30.5 cm maximum. With the open pocket facing up, all length measurements are taken along the center line of the handle.

7. The overall outside width of the head of the crosse when measured at the widest point at the top of the head must be 18 cm minimum to 23 cm maximum. With the open pocket of the head facing up, all width measurements are taken on a line that is perpendicular to the extension of the handle.
8. Sidewall stringing holes: Pockets must be attached to and anchored along the bottom rail of the sidewall through stringing holes. The distance from the bottom of the sidewall to the bottom of the stringing hole shall not be more than 1.0 cm.
Guidance: Decorative holes in the sidewalls that do not meet these specifications may not be used as stringing holes.
9. The entire crosse (strung head and handle) shall not weigh more than 567 g.

B. The Wooden Field Crosse

1. The head of a wooden field crosse is defined to consist of four parts: the Bridge, the Wooden Sidewall, the Guard, and the Scoop. (Diagram 12)
 - a. The bridge is the woven ball stop of a wooden crosse. The height of the bridge shall be 5.1 cm maximum to 3.2 cm minimum.
 - b. As measured from the center of the bridge to the midpoint of the head, the actual height of the wooden sidewall shall be 4.5 cm maximum to 3.2 cm. From the midpoint of the head, the height of the sidewall may taper toward the scoop.
 - c. The guard is the soft woven wall of the head. The height of the guard shall be 7 cm maximum to 3.2 cm minimum.
2. The head shall be triangular in shape. The inside width between the sidewalls of the head must continually increase as measured from the center of the bridge to the widest point at the top of the head.

RULE 25 / MANUFACTURER'S SPECIFICATIONS

- a. The inside width between the sidewalls of the head, as measured 3.2 cm from the center of the Bridge, shall be 6.7 cm to 7.6 cm and the outside width of the head shall be 7.6 cm to 10.1 cm.
 - b. The inside width between the sidewalls of the head, as measured 5.1 cm from the center of the Bridge, shall be 7 cm minimum.
 - c. The inside width between the sidewalls of the head, as measured 7.6 cm from the center of the Bridge, shall be 8 cm minimum.
 - d. The inside width between the sidewalls of the head, as measured 10.2 cm from the center of the Bridge, shall be 9 cm minimum.
 - e. The inside width between the walls at the widest point at the top of the head shall be 15 cm to 16 cm.
- C. Plastic/Molded Head Crosse (Diagram 14)
- I. The head of the plastic/molded head field crosse is defined to consist of four regions: the Throat, the Ball Stop, the Sidewall, and the Scoop. (Diagram 12)
 - a. The ball stop is the center inside curved plastic wall of the head at the throat. The wall of the ball stop must not deviate by more than 5 degrees from perpendicular to the long axis of the handle. To determine crosse compliance with angular measurement specifications in FIL Rule 25, all measurements and calculations will be made to the nearest 0.01°. The allowed deviation from the standard is 0.44°.

Guidance: If the maximum specified angle is 5.0°, then a particular measurement of 5.44° passes, and 5.45° does not.

 - 1) The height of the ball stop shall be 5.1 cm maximum to 3.2 cm minimum.
 - 2) Stop pads shall not be more than 0.5cm thick. With the open pocket of the head facing up, the stop pad shall not vary in thickness from the top to bottom of the ball stop.

RULE 25 / MANUFACTURER'S SPECIFICATIONS

The stop pads may have slightly raised or inset lettering as long as the perceived goal is artistic design/advertising. A series of parallel ridges or grooves are not acceptable. The surface of the stop pad must not in any way interfere with the free movement of the ball within the pocket or effect ball retention.

- b. The stop area ends, and the sidewalls begin as measured 3.4 cm from the center of the ball stop. The sidewalls end, and the scoop area begins at the widest point at the top of the head.
 - 1) From the beginning of the sidewall at 3.4 cm to the midpoint of the head, as measured from the center of the ball stop to the top of the scoop, the actual height of the sidewalls shall be 4.5 cm maximum to 2.8 cm minimum. From the midpoint of the head, the height of the sidewalls may taper toward the scoop.
 - 2) There may be no protrusions or outcroppings on the inside surface of the sidewalls. The sidewalls may not be lined with any additional material.

*Guidance: While no outcroppings or protrusions of any kind are allowed on the sidewalls of a crosse, outcroppings are allowed on the scoop and the ball stop areas as long as *all* other FIL crosse dimension and shape requirements are met, and the outcroppings have only aesthetic function and do not affect the free movement of the ball in the pocket.*

2. The head of the crosse shall be triangular in concept. The inside width between the sidewalls of the head must continually increase as measured from the center of the ball stop to the widest point at the top of the head. (Diagram I3)
 - a. The inside width between the sidewalls of the head, as measured 3.2 cm from the center of Ball Stop, shall be 6.7 cm to 8.0 cm maximum. The radius of the ball is 3.2 cm.

RULE 25 / MANUFACTURER'S SPECIFICATIONS

- b. The inside width between the sidewalls of the head, as measured 5.1 cm from the center of the Ball Stop shall be 7 cm minimum.
- c. The inside width between the sidewalls of the head, as measured 7.6 cm from the center of the Ball Stop, shall be 8 cm minimum.
- d. The inside width between the sidewalls of the head, as measured 10.2 cm from the center of the Ball Stop shall be 9 cm minimum.
- e. The inside width between the walls at the widest point at the top of the head, shall be 16 cm minimum.

Guidance: The inside width between the sidewalls is measured by determining the minimum distance between projections of the sidewalls onto a horizontal plane. This can be performed by measuring the outside distance between two vertical rods.

- 3. At all points along the sidewall, the following formula shall be used to determine the maximum slant/angle the sidewalls may deviate from vertical. (Diagram 15)
 - a. With the open pocket of the head facing up, measure the vertical height of the sidewall at any point. Then find the difference in the width between the top and bottom edges of the sidewall at that point.
 - b. At all points, the difference between the top and bottom widths divided by the vertical height of the sidewall, must be less than or equal to 0.05.

D. The Pockets of all Wooden or Plastic/Molded Field Crosses:

- 1. The pocket of all field crosses shall be strung with 4 or 5 longitudinal leather and/or synthetic thongs and 8 to 12 knots/stitches of cross lacing. Mesh pockets are not allowed.

Guidance: When plastic "zip-ties" are used to attach pocket nylon to thongs, all sharp edges must be sanded/filed smooth.

RULE 25 / MANUFACTURER'S SPECIFICATIONS

- a. Longitudinal leather or synthetic thongs shall be 0.3 cm to 1.0 cm wide. Thongs must not touch, and 'nominally' must be evenly spaced along the length and across the width of the head. Loose ends of thongs may not be woven back up through the pocket of the crosse and during play must be secured to the handle of the crosse. (Diagram 12)
- b. Cross-lacing in a traditionally strung pocket is defined as 8-12 knots/stitches, where two pocket nylons intertwine at a common place on a thong and evenly spaced (not bunched) diamonds. (A 'diamond' is the shape formed between longitudinal knots on thongs and horizontal knots).
- c. Cross-lacing in a pre-manufactured detachable pocket is defined as 8-12 evenly spaced pocket nylon laces that are sewn or traditionally woven between evenly spaced longitudinal thongs. Extra lengths of sidewall nylon ties must be cut to 4 cm maximum.
- d. The nominal diameter of the shooting/throw string and sidewall nylon cord shall be 0.3 cm maximum. The nominal diameter of pocket nylon must be less than 0.3 cm.
 - 1) Field crosses shall have no more than two separate shooting/throw strings. Shooting/throw strings shall not be rolled or coiled more than twice between each thong. Flat hockey or boot laces may not be used as shooting/throw strings.
 - 2) Both shooting/throw strings must be attached in the upper third of the head, or the top shooting/throw string must be attached in the upper third of the head, and the bottom shooting/throw string may be an "inverted "U" in shape and must be attached in the upper one-half of the head, as measured from the top, outside edge of the scoop. (Diagram 16)
- e. All components of the pocket shall be integral, either by tying or by stitching. In no case shall components be slid over the

RULE 25 / MANUFACTURER'S SPECIFICATIONS

shooting/throw strings, cross lacings or thongs. This rule prohibits the use of beads, tubing, or similar items on any part of the pocket.

Guidance: No additional material of any size or shape may be used in the place of traditional knots.

2. The combined height of the sidewall and the depth of the pocket containing the ball must be less than 6.4 cm, the diameter of the ball. The top of the ball, when dropped into the pocket of a horizontally held crosse, must be visible/ seen and remain above the top of the entire wooden or plastic sidewall after reasonable force with one hand has been applied to and released from a ball.
3. The ball must move freely within all parts of the head/pocket both laterally and along its full length. The ball must not become wedged between the walls, under the guard or the bridge of a wooden crosse or in the ball stop or under the walls of a plastic/molded head crosse. The ball must easily fall out of the pocket of the crosse when the crosse is turned upside down.

Guidance: The following are examples that, either alone or in combination, might cause a lack of free ball movement in the head/pocket:

 - Shooting/throw strings that are not interwoven with the cross lacings and thongs and are allowed to sit on top of these other stringing areas.
 - Thongs that are raised above the plane of the pocket.
 - Thongs made from a sticky/tacky substance or this type of substance added to the thongs
4. At any time during play, an umpire may take time out to inspect the pocket of a field crosse, or any player on the field may request an umpire to inspect the pocket of an opponent's crosse. If the ball becomes lodged in a field player's crosse during play, the crosse no longer meets specifications. The umpire shall take time out to remove the illegal crosse to the scorer's/timer's table. To resume play, the opponent nearest to the ball will be awarded a free position for a minor foul.

RULE 25 / MANUFACTURER'S SPECIFICATIONS

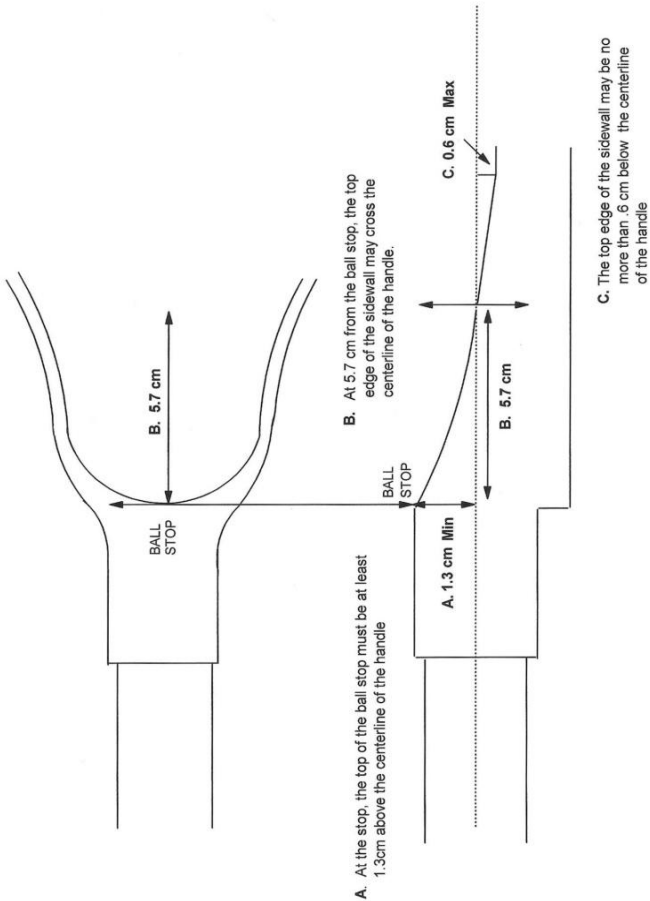

Diagram I I
Offset Specification within 5.1 cm Horizontal Plane
Rule 25.A.5

RULE 25 / MANUFACTURER'S SPECIFICATIONS

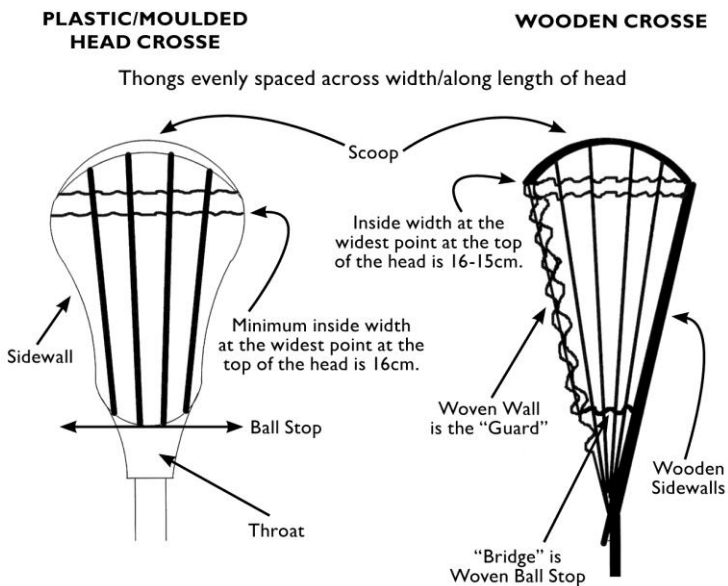

Diagram 12
Parts of Field Crosses

RULE 25 / MANUFACTURER'S SPECIFICATIONS

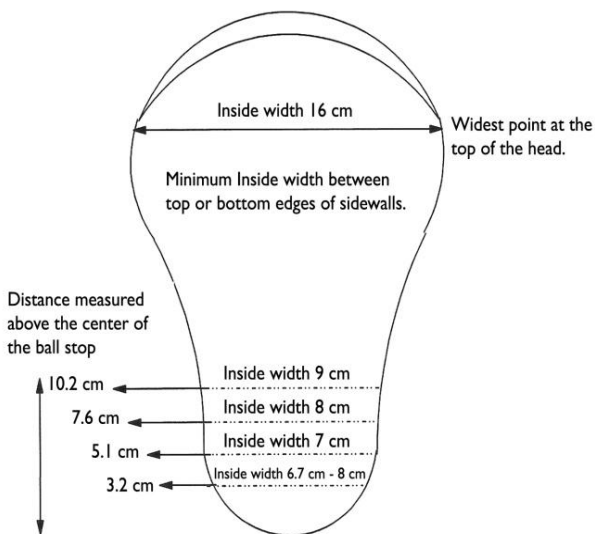

Diagram 13
Triangular in Concept

RULE 25 / MANUFACTURER'S SPECIFICATIONS

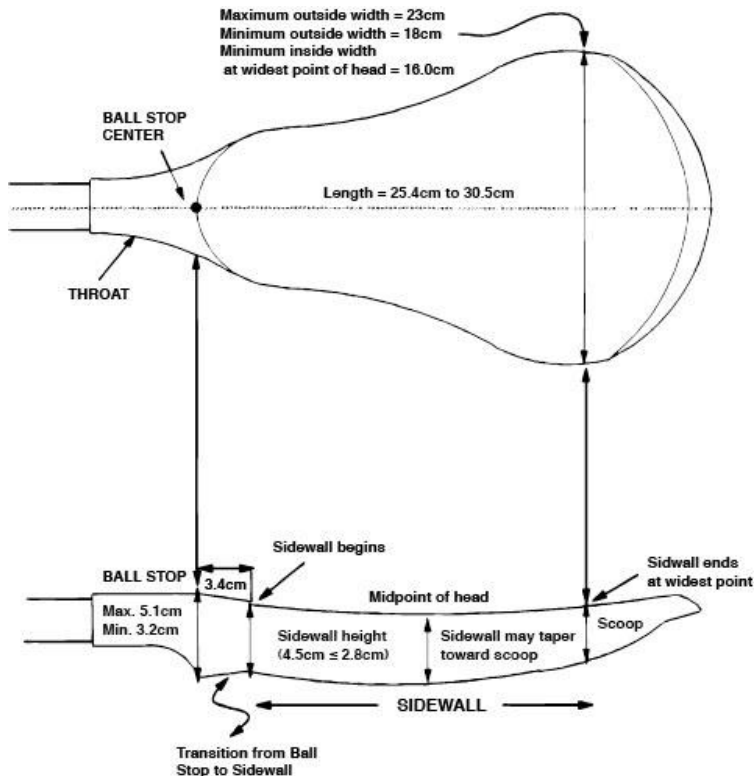

Diagram I4
Plastic/Molded Head Specification

RULE 25 / MANUFACTURER'S SPECIFICATIONS



$$\frac{\text{Bottom Width} - \text{Top Width}}{\text{Vertical Sidewall Height}} < 0.50$$

Diagram 15
Cross Section of Unstrung Head

RULE 25 / MANUFACTURER'S SPECIFICATIONS

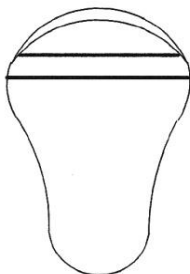

Two separate horizontal throw strings; both attached in upper third of the head

Two separate curved throw strings; both attached in upper third of the head; may not be thick/rolled at point where they cross.

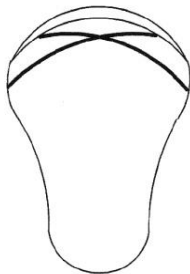

Two separate throw strings; One horizontal across upper third of the head; one inverted "U" in upper one-half of head.

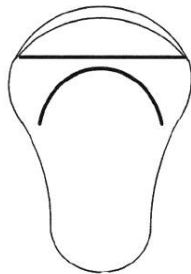

Diagram 16
Shooting/Throw Strings

RULE 25 / MANUFACTURER'S SPECIFICATIONS

- E. The Goalkeeper's Crosse
1. The crosse shall be constructed of wood, plastic, fiberglass, nylon, leather, rubber, gut, and/or any other synthetic material.
 2. The handle of the crosse shall be straight and may be constructed of wood, metal alloy, or other composite material. Recessed metal screws must be used to attach the head to the handle. The butt end of the handle shall have an end cap, be taped or sanded smooth, if wood. The crosse shall not have sharp or protruding parts or edges and shall not be dangerous to players in any way.
 3. The overall length of the crosse shall be .9 m /90 cm minimum to 1.35 m/135 cm maximum.
 - a. To determine compliance with linear measurement specifications, all measurements shall be made to the nearest 0.01 cm. The allowed deviation from the standard is 0.09 cm (Rule 25.A.3.a.)
 4. The unstrung head and the handle of a goalkeeper's crosse shall lie within a 7.6 cm horizontal plane. (See Rule 25.A.4 Guidance to determine the horizontal plane.)
 - a. No part of the head shall pass beyond a plane 2.5 cm above the center line of the handle and/or 5.1 cm below the center line of the handle.
 - b. The top edge of the sidewall shall not be more than 0.6 cm below the center line of the handle.
 5. The head shall have a maximum length of 42 cm. The length of the head is measured from the center of the bridge or ball stop (where the back top edge of the stop pad meets the plastic) to the top outside edge of the scoop. With the open pocket of the head facing up, all length measurements are taken along the center line of the handle.
 6. The height of the bridge or ball stop of a goalkeeper's crosse shall be 5.4 cm maximum to 3.2 cm minimum. The plastic wall of the ball stop must not deviate by more than 10 degrees from perpendicular to the long axis of the handle.

RULE 25 / MANUFACTURER'S SPECIFICATIONS

7. The sidewall begins as measured 3.4 cm from the center of the Bridge or the Ball Stop. The actual height of the wooden sidewall of a wooden crosse and the plastic sidewalls of a molded head crosse shall be 5.1 cm maximum to 2.54 cm minimum. The height of the woven wall of a wooden goalkeeper's crosse shall be 7cm maximum. The sidewall ends at the widest point at the top of the head.
8. The entire head of the crosse shall be triangular in concept. The inside width between the sidewalls of the head must continually increase as measured from the center of the bridge or the ball stop to the widest point at the top of the head. With the open pocket of the head facing up, all width measurements are taken between the plastic or woven and wooden sidewalls on a line that is perpendicular to the center line of the handle. (Rule 25.C.2, Guidance)
 - a. When measured 5.1 cm from the center top edge of the Ball Stop, the inside width between the sidewalls of a plastic/molded head crosse shall be 13 cm to 17 cm. The maximum outside width of the head shall be 20 cm.
 - b. When measured 10.2 cm from the center top edge of the ball stop, the inside width between the sidewalls of a plastic/molded head crosse shall be 18.5 cm to 22.5 cm. The maximum outside width of the head shall be 26 cm.
 - c. When measured 15.3 cm from the center top edge of the ball stop, the inside width between the sidewalls of a plastic/molded head crosse shall be 23 cm to 26 cm. The maximum outside width of the head shall be 30cm.
 - d. At the widest point of the head, the inside width between the walls of the head of the crosse shall be 28.5 cm to 30.5 cm
9. The pocket of the crosse may be strung traditionally with 6 or 7 longitudinal leather or synthetic thongs and 8 to 12 stitches of cross-lacing or MAY BE MESH.
 - a. The goalkeeper's crosse may have more than two shooting/throw strings and flat hockey/boot laces may be used as

RULE 25 / MANUFACTURER'S SPECIFICATIONS

shooting/throw strings. There are no restrictions regarding the design or placement of shooting/throw in the pocket of the crosse.

10. The depth of the pocket containing the ball may be unlimited except that the ball must move freely within all parts of the head both laterally and along its full length. When the crosse with the ball in it is held at eye level with the long axis of the stick vertical to the ground, more than half of the ball must be seen above the ball stop
11. The crosse (strung head and handle) shall not weigh more than 773g.

Guidance: The intent of the rules governing the head design of a goalkeeper's crosse is to disallow crosses where excessive widths of plastic are added to the sidewalls to increase the surface area of the head.

F. The Goal and Goal Netting (Rule 2 & Diagrams 4 & 5)

G. The Ball (Rule 4)

NOTE: All FIL approved women's crosses are evaluated in a certified laboratory for compliance to written measurement and pocket design standards. The test facility will accept pre-production models (also known as SLAs or rapid proto-types) for evaluation; however, only preliminary approval will be granted if the pre-production model meets all specifications.

Final approval will be contingent on a final product model being submitted to the laboratory, evaluated and meeting all specifications. Once the test facility has determined that a crosse meets all the specifications in Rule 25, a report will be sent to the FIL, and the stick will be listed on the FIL web site as approved immediately for international play. **Exception:** For all FIL Women's World Events, players may use only those crosses that have been evaluated and approved by the Laboratory three months (90 days) prior to the scheduled first day of play.

RULE 25 / MANUFACTURER'S SPECIFICATIONS

Specifications for all equipment are reviewed annually and modified periodically by the FIL rules committee. The FIL will endeavor, when possible, to provide advance notification of changes to equipment specifications to the manufacturers of crosse equipment known to the FIL. However, the FIL reserves the right to change any equipment specifications at any time, if, in its sole discretion, the FIL deems the changes to be in the best interest of the sport of women's lacrosse.

The FIL shall have no liability for any consequence deriving from the choice of equipment used by players, any defects it may have, or for alterations made to the crosse by players after the crosse is manufactured.

APPENDIX A

UMPIRE ARM SIGNALS (Descriptive)

BLOCK: Place open hands on hips and move them in an in-out motion touching hips.

CHARGE / OFFENSIVE FOUL: Place the palm of one hand behind head and give direction of play with the other hand.

COVER: Extend arms in front of body with one palm on top of the other.

DANGEROUS FOLLOW-THROUGH: Mimic the follow-through motion as if holding a crosse.

DANGEROUS PROPELLING: Mimic a two-handed follow through motion or the side arm swing as if holding crosse.

DANGEROUS SHOT ON GOALKEEPER: Open the palm of one hand and move in toward face.

DETAINING: Place fists at waist level, one fist up and the other down, as if holding a crosse in a horizontal position.

EMPTY CROSSE CHECK: Use the right hand with a clapping motion on the left hand.

FREE POSITION, DIRECTION OF POSSESSION, and HELD WHISTLE: Hold one arm horizontally at shoulder height in the direction of play.

GOAL: Facing the center of the field, raise both arms straight above the head and then lower them to chest level pointing horizontally toward the center of the field.

GOAL CIRCLE FOUL: Point to the goal circle line and then indicate direction of the free position.

APPENDIX A / UMPIRE ARM SIGNALS (Descriptive)

HELD CROSSE: Use the right hand with a clapping motion on the left hand and then briefly hold hands together

ILLEGAL BALL OFF BODY: Indicate by pointing to the part of a player's body used to 'deliberately' play the ball.

ILLEGAL CHECK TOWARD HEAD: Make a chopping motion with hand toward the head.

ILLEGAL CHECK ON THE BODY: Make a chopping motion with one hand on the part of the body where contact was made.

ILLEGAL CRADLE / PROTECTING THE CROSSE: Make a cradling motion with one hand pulled in close to the face or body.

ILLEGAL STICK TO BODY CONTACT: Fisted hands, one fist facing up and the other down, are held horizontally at waist level. Extend arms forward in a pushing motion. (Rule 20.A.13)

NO GOAL: With both arms extended toward the ground, swing them in and out so they cross one another; follow this motion with a direction signal.

OBSTRUCTION OF THE FREE SPACE TO GOAL: Arms are held at chin level with palms toward face and finger tips facing up. One hand is closer to the face; hands are in a line and about 16 cm apart.

PUSHING: Make a pushing motion with both arms, palms open and in front of body.

RE-DRAW: Place arms fully extended horizontally in front of the body. Begin with palms together and extend them up and out with a quick motion.

APPENDIX A / UMPIRE ARM SIGNALS (Descriptive)

RESTRAINING LINE VIOLATION: One arm is raised straight over head with palm open. Close the fist when making the call.

ROUGH / ILLEGAL CHECK ON BODY: Use the arm to make a large chopping motion against the wrist of the opposite arm.

SWIPE: Move one arm in a large circular motion around the head or make a long sweeping motion with an extended arm from high to low across the body.

TEN-SECOND GOAL CIRCLE COUNT: Bend one arm at shoulder height and move arm from chest to full extension for each second counted.

THREE SECONDS: Three fingers are raised with palm facing away.

TIME OUT: Turn toward the scorer/timer and cross fully extended arms at wrists above the head.

TRIP: Swing hand across the back of the leg at or below the knee.

THROW: Hold both fisted hands in front of the body with thumbs up; and move fists up vertically.

WARD OFF: Bend one forearm and move it in an upward motion away from the body.

APPENDIX A / UMPIRE ARM SIGNAL (Visual)



APPENDIX A / UMPIRE ARM SIGNALS (Visual)

 <p>BLOCKING</p>	 <p>CHECKING INTO THE SPHERE</p>	 <p>DANGEROUS FOLLOW THROUGH & DANGEROUS PROPELLING</p>	
 <p>DANGEROUS SHOT ON GOALKEEPER</p>	 <p>DETAINING</p>	 <p>EMPTY CROSSE CHECK</p>	 <p>HELD WHISTLE DIRECTION OF POSSESSION</p>
 <p>ILLEGAL STICK TO BODY CONTACT</p>	 <p>GOAL CIRCLE FOUL</p>	 <p>ILLEGAL CRADLE IN SPHERE</p>	 <p>ILLEGAL BALL OFF THE BODY</p>
 <p>ILLEGAL CRADLE IN SPHERE</p>	 <p>NO GOAL</p>		

APPENDIX B

FIL WOMEN'S PRE MATCH SCHEDULES

- 35 minutes prior to the game, teams and umpires must be on the field to complete match preparation. Scorers, timers, and technical delegates report to the score table. When looking at the field from the team bench areas, the higher seeded team will sit to the right of the score table.
- 20 minutes prior to the game, completed team rosters must be submitted to scorers.
- 15 minutes prior to the game, ball girls/boys must report to the score table for instructions.
- 10 minutes prior to the game, teams will report to their bench areas for crosse checks.
- Immediately following crosse check, teams line up for player/team introductions, playing of respective national anthems, and exchange of pins.
- Team captains meet with the umpires to toss a coin for choice of defensive ends.
- Teams are guaranteed two (2) minutes immediately following the coin toss before the game begins.

FIL WOMEN'S POST-MATCH SCHEDULE

- Teams have 10 minutes to cool down on the game field and in the team bench areas. The 10 minutes countdown starts at the sound of the horn/whistle that ends the game.
- Media are not allowed on the game field for interviews with players or coaches.
- At zero minutes on the post-game clock, teams must remove all belongings from the team bench areas, leave the field, and go to the designated area for interviews with media.

APPENDIX C

FIL POLICY REGARDING BLOOD ON UNIFORMS, SKIN, EQUIPMENT AND SURFACES

Whenever a participant suffers a laceration or wound where oozing or bleeding occurs, an umpire will stop the game at the earliest appropriate time, and the player or umpire will be required to go to the team bench area to receive medical treatment. The participant that has been removed shall not re-enter the game without approval of medical personnel.

If there is blood on any part of a player's uniform, skin, or other personal equipment, medical personnel must determine whether the blood has saturated the uniform or equipment enough to require a change. A uniform is considered saturated when blood has soaked through the uniform to a player's skin or is capable of being transferred to another player. The same saturation criteria should be applied to a player's personal equipment (stick, gloves, pads, knee brace, etc.) If the uniform shirt is changed, the player's new number must be recorded on the team score sheet before the player re-enters the game. It is recommended that teams travel with extra uniforms.

Before the game is restarted, appropriate medical personnel must clean and decontaminate any and all surfaces that are contaminated with blood, including the playing field if necessary.

In the event of an injury, time out will be called at the discretion of the umpire. If, in the umpire's opinion, the injury is serious or the player's safety is compromised in any way, the umpire will suspend play immediately. Otherwise, the umpire may delay the whistle to allow a team to complete a scoring play. When time out is called, the umpire will beckon team medical personnel onto the field to attend to the injured player.

If a field player is not ready to resume play after two minutes recovery time or a goalkeeper is not ready to resume play after five minutes recovery time, a substitute must take her place. However, if a player sustains a serious injury, play will be suspended until the injured player can be safely moved off the field and a substitute has taken her place.

APPENDIX D

FIL GAME INTERRUPTION POLICY

LIGHTNING

The decision to suspend a game due to lightning and/or thunder will be made by the umpires and game officials on the field at the time of play. During a tournament, if two games are being played at the same time, the decision made on one field will be communicated to the other field and followed.

The Head Technical Delegate, the FIL Competitions Chair, and representatives from the Host Committee will communicate daily to monitor weather forecasts and communicate possible weather concerns to game officials and umpires. They will be instructed to actively look for signs of bad weather throughout each game and notify the umpires/game officials on the field if severe weather becomes dangerous.

If at any time, the Head Technical Delegate, the FIL Competitions Chair, and/or a designated member of the Host Committee determines that play should be interrupted, they shall inform the nearest umpire on the field and/or the reserve table umpire to suspend play immediately. The head on-field umpire and/or table umpire must note the time of the stoppage on the team score sheet.

In the absence of technology to assist with weather evaluation, games will be suspended when the “*flash to-bang*” count for lightning is less than 30 seconds. (See **NOTE** below)

Once a game is suspended, the technical delegates will assist event staff to quickly evacuate teams and spectators to predetermined safe shelter. Teams and field umpires will go to their respective locker rooms or other safe shelter, and spectators will be instructed to proceed to their automobiles or designated adjacent buildings.

Players may take the field, and spectators may return to the stands 30 minutes after the last visible lightning flash or sound of thunder. The decision to resume play will be made by the head on-field umpire, in consultation with the Head Technical Delegate, the FIL Competitions Chair, and/or a designated member of the Host Committee.

APPENDIX D / FIL GAME INTERRUPTION POLICY

Resuming Play Following a Game Interruption

If a game is stopped / interrupted due to severe weather, the remaining time in the game will be played as soon as possible; the score will resume from the point of interruption. The Head Technical Delegate and the FIL Competitions Chair will make the decision as to when the game will resume.

Following a game interruption, teams will be allowed to warm-up as follows:

- If the delay is not more than 30 minutes, a 10-minute warm-up will be allowed.
- If the delay is between 30 and 60 minutes, a 15-minute warm-up will be allowed.
- If the delay is more than 60 minutes, a 20-minute warm-up will be allowed.
- By mutual consent of both coaches, the above warm-up time may be shortened.

NOTE: The following "Flash to Bang" method should be used to estimate the proximity of lightning from your location. If the delay between observing a lightning flash and hearing subsequent thunder is 30 seconds or less, or if dangerous looking thunder clouds are building overhead, the lightning safety action plan must be implemented without delay.

When lightning occurs, count the number of seconds until thunder is heard. Divide the number of seconds by 5 to determine how far the lightning is away from you. Example: If lightning is seen and 30 seconds elapses before thunder is heard, the lightning is 6 miles / 9 km away, 30 divided by 5 = 6 miles.

APPENDIX E

EXCESSIVE HEAT

Water breaks of no longer than 1:30 minutes/90 seconds in length will be incorporated into each game if, in the opinion of attending medical personnel, they become necessary. In women's play, those breaks will occur as close to the mid-point of each half as possible, after a goal, or at a midfield dead ball between the restraining lines.

FIL Water Break Procedures

1. Forty-five (45) minutes before each match begins, **personnel*** from the host country will determine if water breaks are necessary and inform the Technical Delegate in charge of the match. Team coaches will be informed when the teams take the field for the 35 minute pregame warm-up. If water breaks are necessary, they will occur in both periods of the match. Water breaks may also be implemented at half time.
2. If one water break per half is required, it will be taken as close as possible to 15 minutes on the game clock. If two water breaks per half are required, they will be taken as close as possible to 20 and 10 minutes on the game clock.
3. The water break will be 90 seconds in length, and with 30 seconds remaining, teams must break to take the field.
4. The water break will be taken after a goal is scored, or on a midfield dead ball between the restraining lines; this includes side line out of bounds balls.
5. The Technical Delegates will manage the water breaks to ensure that no coaching or substitutions takes place during the water break.
6. All players on the field must remain on the field until the end of the water break. They may come to the side of the field to get drinks.
7. Substitutes must remain in the team bench area until the end of the water break.
8. If the water break is after a goal, a substitute may enter the game at the end of the water break. If the water break occurs at midfield on a dead ball, a substitute must enter the game through the substitution area once play resumes.

APPENDIX E / EXCESSIVE HEAT

9. When a water break is called after a goal has been scored, a team may not request a team time out at the end of the water break. They must wait to request a team time out until after the next goal is scored.
10. If a team wishes to take a time out at the same time as a scheduled water break after a goal is scored, the team time out will override the water break. Another water break will not be scheduled to replace it.

***Personnel:** For each world event, it is the host country's responsibility to identify a person/s who will be responsible for instituting water breaks in accordance to the above criteria when temperature and/or humidity levels are deemed dangerous to the health of the athletes. When necessary, water breaks will be discussed at the managers' meeting prior to an FIL Women's World Event.